

POLANIK
Poland, Życzliwa 11
97-300 Piotrków Trybunalski

tel. +48 44 646 44 81
tel. +48 44 648 50 89
fax +48 44 646 43 58

e-mail: info@polanik.com
www.polanik.com



TECHNICAL SPECIFICATION

Competition steel starting block with high foot supports

PBS15-01-W

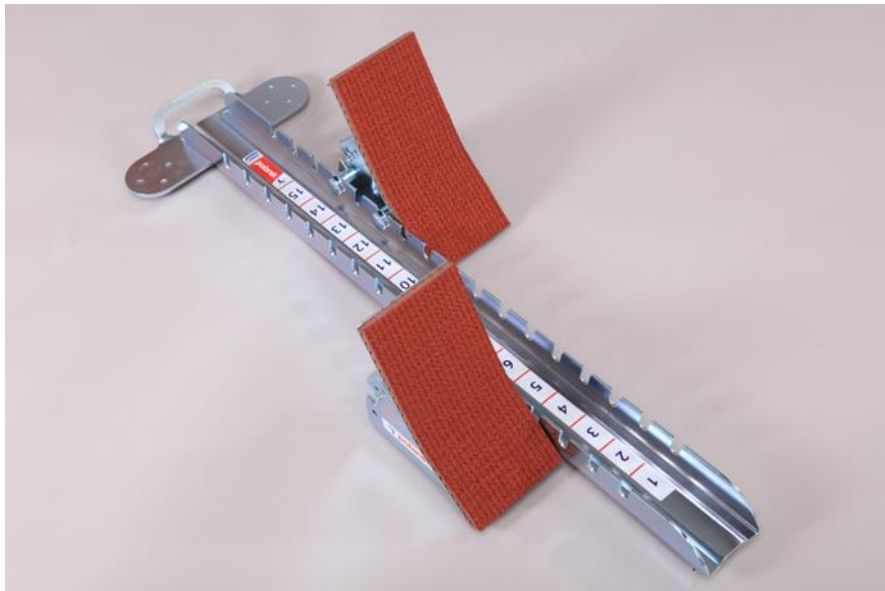

File: 2017-12-12
PRODUCT SUPPORT
Paweł Ciechanowski
p.ciechanowski@polanik.com



Contents

Chapter	Page
I. General description and use	2
II. Technical specification	3
III. Operation and maintenance	4
IV. Packing and transport	4
V. IAAF Certificate	5

I. General description and use

PBS15-01-W has got a solid steel construction. The block is designed for athletics competition and training of races up to and including 400 m (including the first leg of the 4x200 m and 4x400 m). Special high foot supports ensure a better foothold than standard ones.

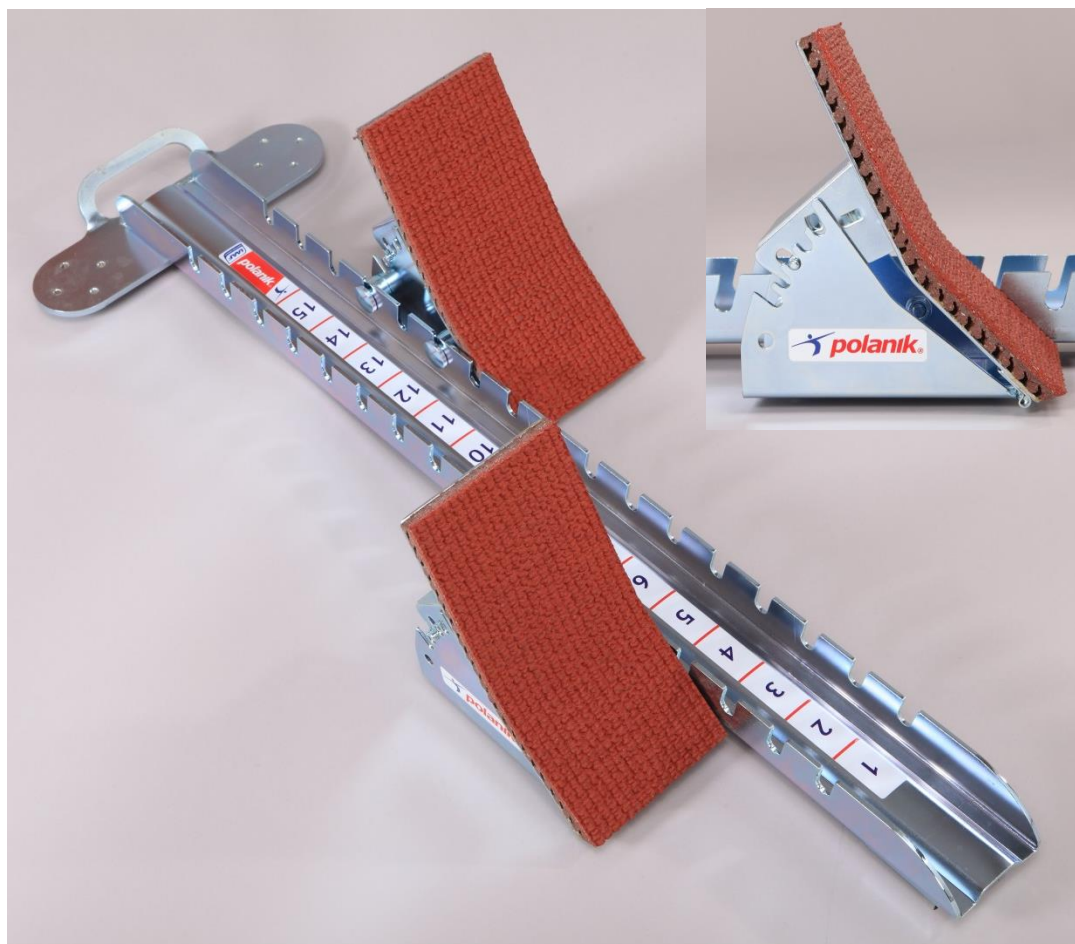

PBS15-01-W © 2017 Polanik

The producer reserves the right to introduce without warning changes in product constructions and colours.

II. Technical specification

Code	PBS15-01-W
Type	IAAF certified, competition steel
Use on	synthetic track only
Block rail	steel galvanized profile, with handle, 15 support positions
Casing of foot support	steel galvanized, two fastening bolts, 5 foot support inclinations
Foot support	high, steel galvanized profile, of ergonomic shape, with synthetic track
Adjusting lever of support inclinations	steel galvanized profile, spring loaded
Block length [mm]	~900
Block width [mm]	~295
Block rail width [mm]	70
Block rail height [mm]	49
Max. foot support height [mm]	~216
Net weight [kg]	8

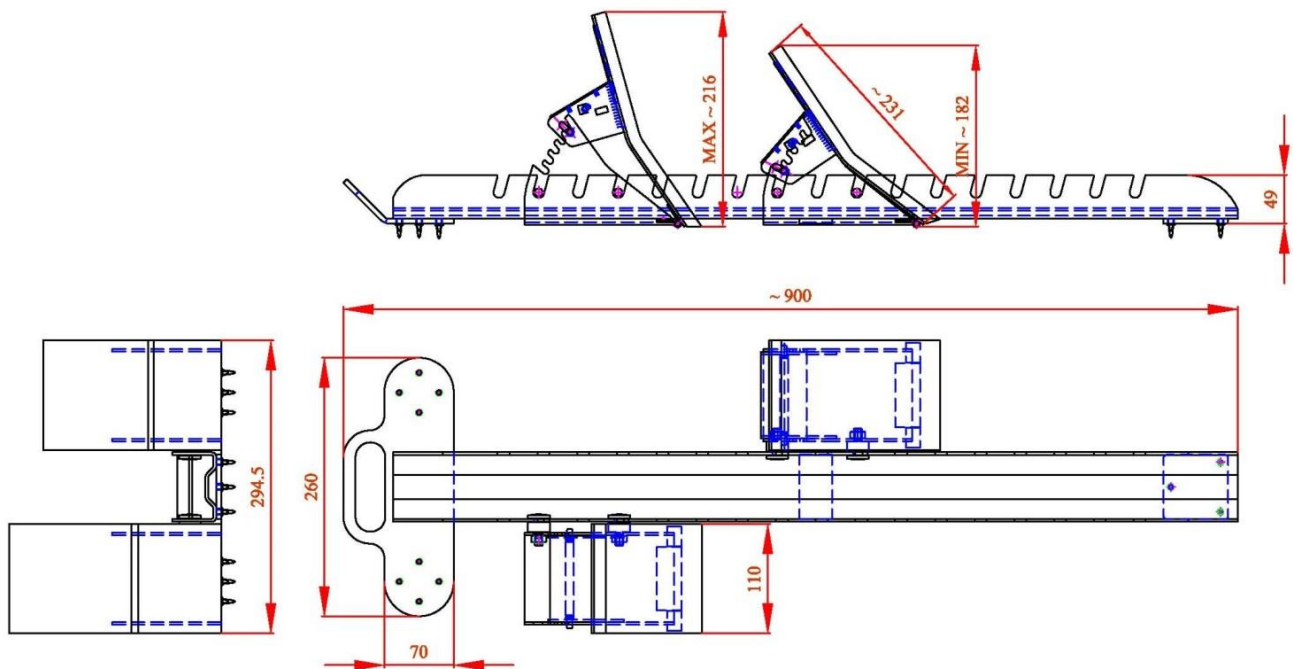

[mm]

III. Operation and maintenance

The starting blocks must be stored in a roofed and dry place. The product does not require any special maintenance proceedings.

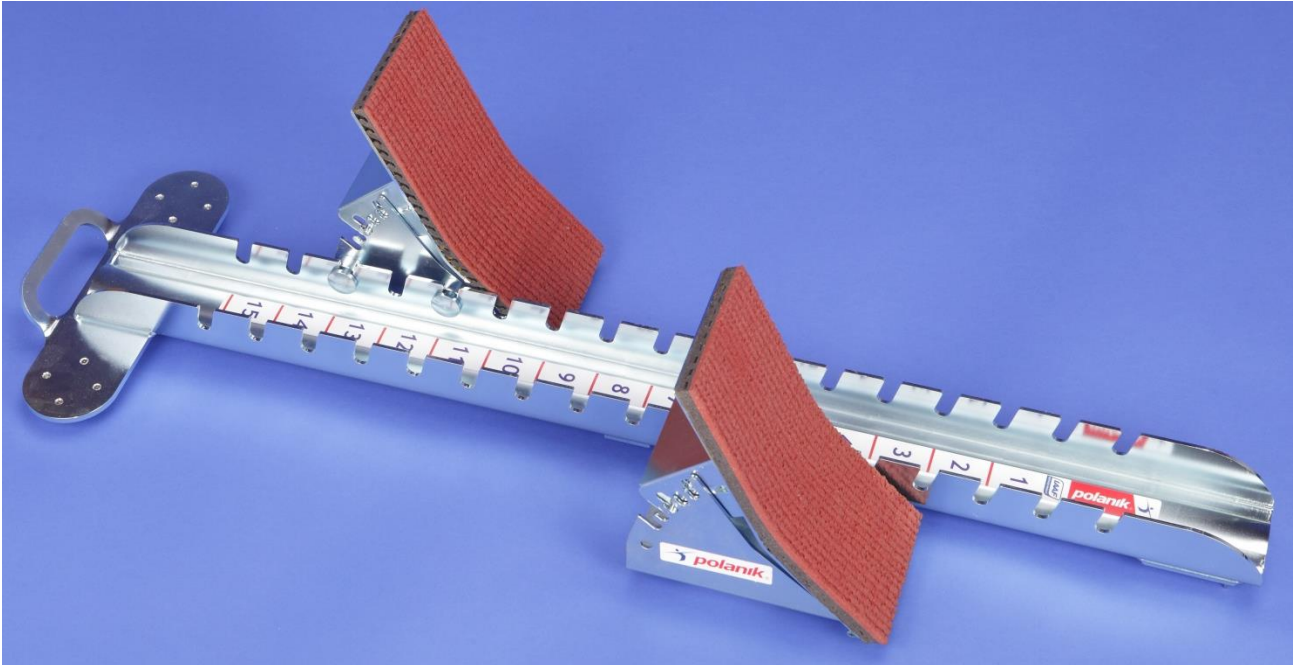

IV. Packing and transport

The starting block is packed in a carton box:

Box's dimensions [m]	contents	1 pc	2 pcs
	length L	0,92	0,92
	width B	0,34	0,34
	height H	0,18	0,18
Volume [m ³]		0,056	0,056
Gross weight [kg]		9	17

V. IAAF Certificate

International Association of Athletics Federations



Product Certificate

*The IAAF is pleased to certify hereby
that the following product:*

Product's Trade Name: Starting blocks, Competition

Description, Colour / Absolute Thickness: Steel, high foot supports, Metal

Company Name, Country: Polanik Sp. z o. o. - Sp. K., POL

Catalogue Number: PBS15-01-W

IAAF Certification Number: E-13-0735

meets the dimensional requirements for use in all international athletics competitions.

It is for the purchaser to determine the item's fitness for the purpose based on his knowledge of the local conditions and use.

Valid from: 1 December 2017

Until the last day of: December 2021

This certificate is issued in accordance with the terms and conditions of the IAAF Certification System of track and field facilities, implements and competition equipment.



SEBASTIAN COE
IAAF President



JORGE SALCEDO
IAAF Technical Committee Chairman

