

POLANIK
Poland, Życzliwa 11
97-300 Piotrków Trybunalski

tel. +48 44 646 44 81
tel. +48 44 648 50 89
fax +48 44 646 43 58

e-mail: info@polanik.com
www.polanik.com

 **polanik**[®]
we help to win

ASSEMBLY MANUAL

Competition safety cage for discus and hammer throwing

KLM-7/10-A

Recommended by



Szymon Ziółkowski
Olympic Champion



File: 2016-12-06
PRODUCT SUPPORT
Pawel Ciechanowski
p.ciechanowski@polanik.com



Thank you for purchasing POLANIK cage type KLM-7/10-A.

Safe assembly and use

- Before you start to assemble and use the cage please read this manual carefully, watch the enclosed instruction film and store the manual in a safe place for further reference. Polanik Sp. z o. o. shall not be liable for any cage damages which are the result of the failure to follow this manual.
- Unauthorized copying of this manual, in whole or in part, is prohibited.
- The contents of this manual are subject to change without notice.
- Warning! The sports equipment produced by Polanik Sp. z o. o. is designed for athletics training and use in sports competitions only. Please pay special attention especially when using throwing implements and other throwing equipment, misuse of athletics equipment and implements can cause serious injury or in extreme cases even death. That is why training and use during sports events have to be always supervised by authorized sports personnel. In no event shall Polanik Sp. z o. o. be liable for any special, incidental, indirect or consequential damages in connection with the purchase or use of POLANIK products or costs over the original cost of the product.
- Specific warranty terms:
 - 1) The use of the throwing cage (KLM-7/10-A) is to be done in the properly marked and secured sports facility designed for that purpose and under supervision of qualified coaches, and according to: the rules of the International Association of Athletics Federations (IAAF), respective national athletics federation and local safety regulations. Failure to follow the above restrictions results in loss of the warranty rights.
 - 2) The throwing cage (KLM-7/10-A) is designed to protect the spectators against the improperly released hammer (discus) which misses the cage mouth. The execution of that task brings a risk of damages to the cage elements (for example the pillars), as a crumple zone of an automobile is damaged to absorb energy from the impact during an accident to save passengers. The damages caused by the proper cage operation, which is stopping improperly thrown hammers (discuses) from flying outside the cage and absorbing the impact energy in order to protect the thrower inside the throwing circle, are recognized as a normal wear of the product and are excluded from the warranty. The damages can be removed in course of payable repair or replacement of the cage elements.
 - 3) **The use of the non-genuine spare parts (not produced by Polanik) results in loss of the warranty rights and the termination of the IAAF certificate validity.**



Contents	
Chapters	Page
Safe assembly and use	2
I. Characteristics of the hammer/discus safety cage KLM-7/10-A	3
II. Parts list	4
III. General assembly description	7
IV. Anchors – placing in concrete	8
V. Pillars installation	9
VI. Net hoisting	14
VII. Final adjusting	16
VIII. Maintenance and periodical inspection	16
IX. Technical drawings	17
Drawing no. 1 – Central cage pillar	17
Drawing no. 2 – Rear cage pillar	18
Drawing no. 3 – Cage gate and extreme pillar	19
Drawing no. 4a – Foundation block for rear and central cage pillars	20
Drawing no. 4b – Foundation block for cage extreme pillars	21
Drawing no. 5 – Plan of the cage	22
Drawing no. 6 – Plan of the foundation blocks for cage pillars	23
Drawing no. 7 – Pillars installation	24
Drawing no. 8 – View of the mounted cage	25
X. How to play the attached instructional video	26
XI. IAAF Certificate	27

I. Characteristics of the cage



We would like to thank you for choosing POLANIK cage type KLM-7/10-A. The safety cage for hammer and discus throwing is a modern construction made of high quality materials. Main characteristic features of the cage are as follows:





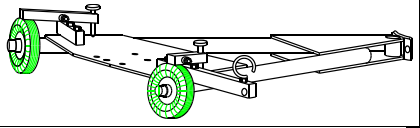
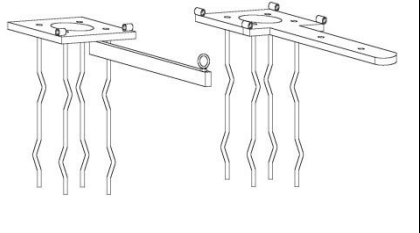
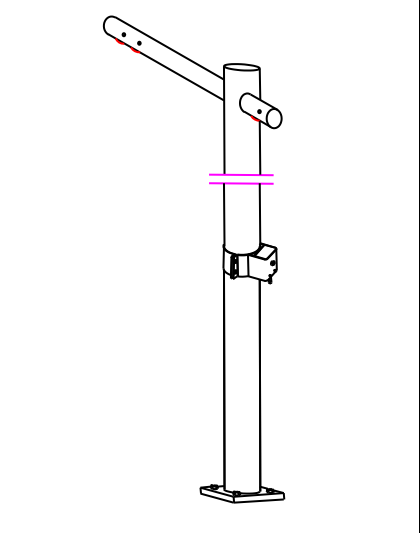
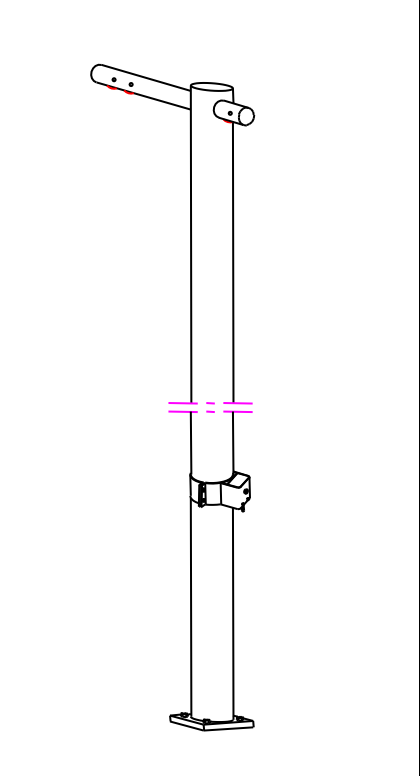

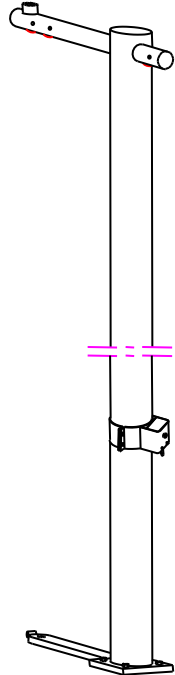
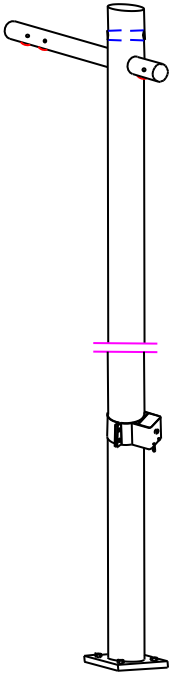
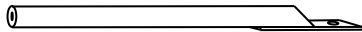
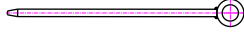

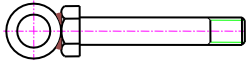

1. Innovative construction:
 - Net is hung in such a way that it does not touch the aluminium structure in any point. That is attained by means of the one-pillar mobile door construction. It is a unique solution, which cannot be spotted in other constructions – protected by patent.
 - Cage pillars are not linked with each other by means of inflexible elements, that is why they work independently.
 - Application of anchors (instead of popular sockets) eliminates rusting caused by water penetration in the lower parts of the cage.
2. High durability:
 - Cage construction is made of aluminium which is anodized in silver colour.
 - All tube ends are protected with plastic caps. They stop water from getting inside the construction and provide good finish and appearance.
 - Steel elements are hot galvanized or electro-galvanized. All ratchet mechanism casings are additionally coated with powder paint.
3. High quality:
 - Cage conforms to the international quality standards confirmed by the certificate of International Association of Athletics Federations (IAAF).
 - Cage is equipped with high quality, certified net. Net is strained and fastened at the cage bottom by means of steel cable and hooks. That lets us eliminate traditional bags filled with sand.
4. Easy operating:
 - Cage can be assembled and disassembled without using a crane or an extension arm. Assembly (or disassembly) using POLANIK cage gate lift CGL-3 takes approximately 4÷5 hours done by 3÷4 people. When the lift CGL-3 is not used 6÷8 people are required to install the cage gate.
 - Pillars are fastened to anchors embedded in concrete. That system of pillar installation enables you to dismount the cage and cover the anchor foundations with synthetic surface in order to use the ground for other purposes.
 - Each pillar is equipped with the self-blocking mechanism of lifting and lowering the net by means of crank.
 - Each gate door moves on two widely spread rubber wheels what makes the gate very stable.

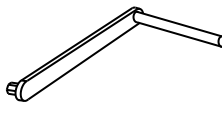
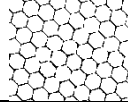
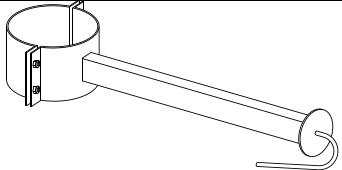
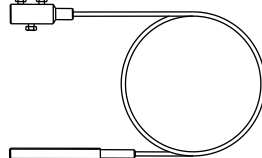
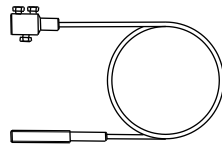

We deliver the cage to a customer in partially assembled units. Assembly should be conducted according to this manual and enclosed instruction film.

II. Parts list (parts sets)

Item	Part/set description	Q-ty Pcs.	Material	Drawin g no.	Part/set sketch
1	Gate car	2	Hot galvanized steel	3, 8	
2	Anchor (8 pcs) + extreme pillar anchor (with flat bar – 2 pcs) + screw M 20x50 (44 pcs) + washer 20 (44 pcs)	8+2	Electro-galvanized steel	1, 2, 3, 4,8	
3	Rear pillar (length approx. 7 m)	6	Anodized aluminium and electro-galvanized steel	2, 8	
4	Central pillar (length approx. 10 m)	2	Anodized aluminium and electro-galvanized steel	1, 8	

Item	Part/set description	Q-ty Pcs.	Material	Drawin g no.	Part/set sketch
5	Extreme pillar (length approx. 10 m)	2	Anodized aluminium and electro-galvanized steel	3, 8	
6	Gate pillar (length approx. 10 m) + screw M 20x60 (8 pcs) + nut M 20 (8 pcs) + washer 20 (8 pcs)	2	Anodized aluminium and electro-galvanized steel	3, 8	
7	Upper gate arm	2	Hot galvanized steel	3, 8	
8	Hinge axle \varnothing 11 x 350	1	Electro-galvanized steel	7B/7C/ 7D	
9	Car sleeve \varnothing 20 / \varnothing 30	2	Electro-galvanized steel	3	

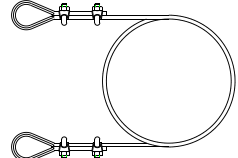
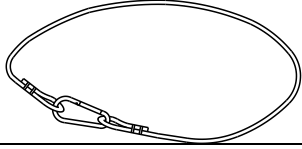
Item	Part/set description	Q-ty Pcs.	Material	Drawin g no.	Part/set sketch
10	Car axle screw M 20x120	2	Electro-galvanized steel	3	
11	Washer $\varnothing 20 / \varnothing 40 \times 3$	2	Electro-galvanized steel	3	
12	Upper arm sleeve	2	Electro-galvanized steel	3	
13	Press bolt M 16x40	2	Electro-galvanized steel	3	
14	Clamping screw for upper arm M 20x160	2	Electro-galvanized steel	3	
15	Blocking washer Nord-Lock 20	2	Electro-galvanized steel	3	
16	Crank	2	Electro-galvanized steel	1, 2, 3, 8	
17	Net with rim white rope	1	-	8	
18	Side cable arm + screw M 8x25 (16 pcs) + nut M 8 (16 pcs) + washer 8 (16 pcs)	4	Electro-galvanized steel and powder painted	3, 8	
19	Bottom net tension cable length approx. 25,8 m + nut M 16 (1 pc) + washer 16 (1 pc)	1	Electro-galvanized steel	8	
20	Gate car net tension cable length approx. 2 m + nut M 16 (1 pc) + washer 16 (1 pc)	2	Electro-galvanized steel	8	
21	Net hooks	100	Electro-galvanized steel	8	
22	Blocking pin	2	Electro-galvanized steel	3, 8	
23	Blocking sleeve	4	Electro-galvanized steel	3, 8	

Item	Part/set description	Q-ty Pcs.	Material	Drawin g no.	Part/set sketch
24	Edge steel cable of the gate panel length ~9,8 m (threaded through the net meshes)	2	Electro-galvanized steel	3, 8	
25	Horizontal stay ropes length ~1,6 m	10	-	8	
26	Blocking washer Nord-Lock 16	2	Electro-galvanized steel	3	
27	Metric wrench 30/24 for mounting upper gate arm item 7	1	-	-	

III. General assembly description

The sequence of the assembly operations is described in detail in the next chapters of this manual. The instruction film on the enclosed CD-ROM also presents the assembly process. We ship the cage to a customer in partially assembled units. Extension arm with rollers and ratchet mechanism is already installed in each cage pillar (see drawing no. 1, 2 and 3). The cage construction consists of 12 pillars: 6 central pillars 7 m high (item 3, drawing no. 2 and 8), 2 central pillars 10 m high (item 4, drawing no. 1 and 8), 2 extreme pillars 10 m high (item 5, drawing 3 and 8) and 2 gate pillars 10 m high (item 6, drawing no. 3 and 8). Central pillars differ from rear pillars only in diameter, the latter ones are thinner. Extreme pillars have got bigger diameter, two pairs of hinges and special flat steel welded to their feet. Gate pillars (item 6, drawing no. 3 and 8) have got mounting holes at their top ends for installing upper gate arms (item 7). Gate pillars are fastened to gate cars (item 1) and they constitute the cage gate. Rear, central and extreme pillars are fastened to anchors (item 2, drawing no. 4a and 4b), which are embedded in concrete according to the plan of the foundation blocks – drawing no. 6. The anchors for rear and central pillars should be positioned in concrete in such a way that their hinges face the throwing circle. The anchors for extreme pillars are fixed in concrete in such a way that their flat bars point to the inside of the cage. Installed pillars constitute the main structure of the cage which is ready for affixing the net and hoisting it.

IV. Anchors – placing in concrete

The anchors for rear and central pillars should be positioned in concrete so that **their hinges face the throwing circle.** The anchors for extreme pillars ought to be positioned in concrete so that **their flat bars face the inside of the cage.** **Attention!** All anchors (item 2, drawing no. 4a, 4b, 1, 2 and 3) must be embedded in the foundation blocks in such a way that their upper surfaces are exactly horizontal, then pillars will be precisely in vertical position. **Each anchor must be fixed according to the direction marks, see drawing no. 6.** During the embedding process please make sure that the screws situated in the upper plates of the anchors are fully screwed down and their threads are well protected by rubber sleeves. If concrete plasters the threads of the screws it will be impossible to install the pillars. Foundation blocks are shown in drawing no. 4a and 4b.

There are special direction marks painted on each anchor (drawing a and b). Drawing b is showing the anchors for extreme pillars (item 5, drawing no. 3 and 8). Drawing a is presenting the anchors of rear and central pillars. All direction marks on the anchors must correspond with the direction lines in drawing no. 6. The positions of the anchor hinges should be also checked and compared with drawing no. 6. All supplied anchors are ready for embedding (screws are fully screwed down and their threads coated with rubber sleeves).

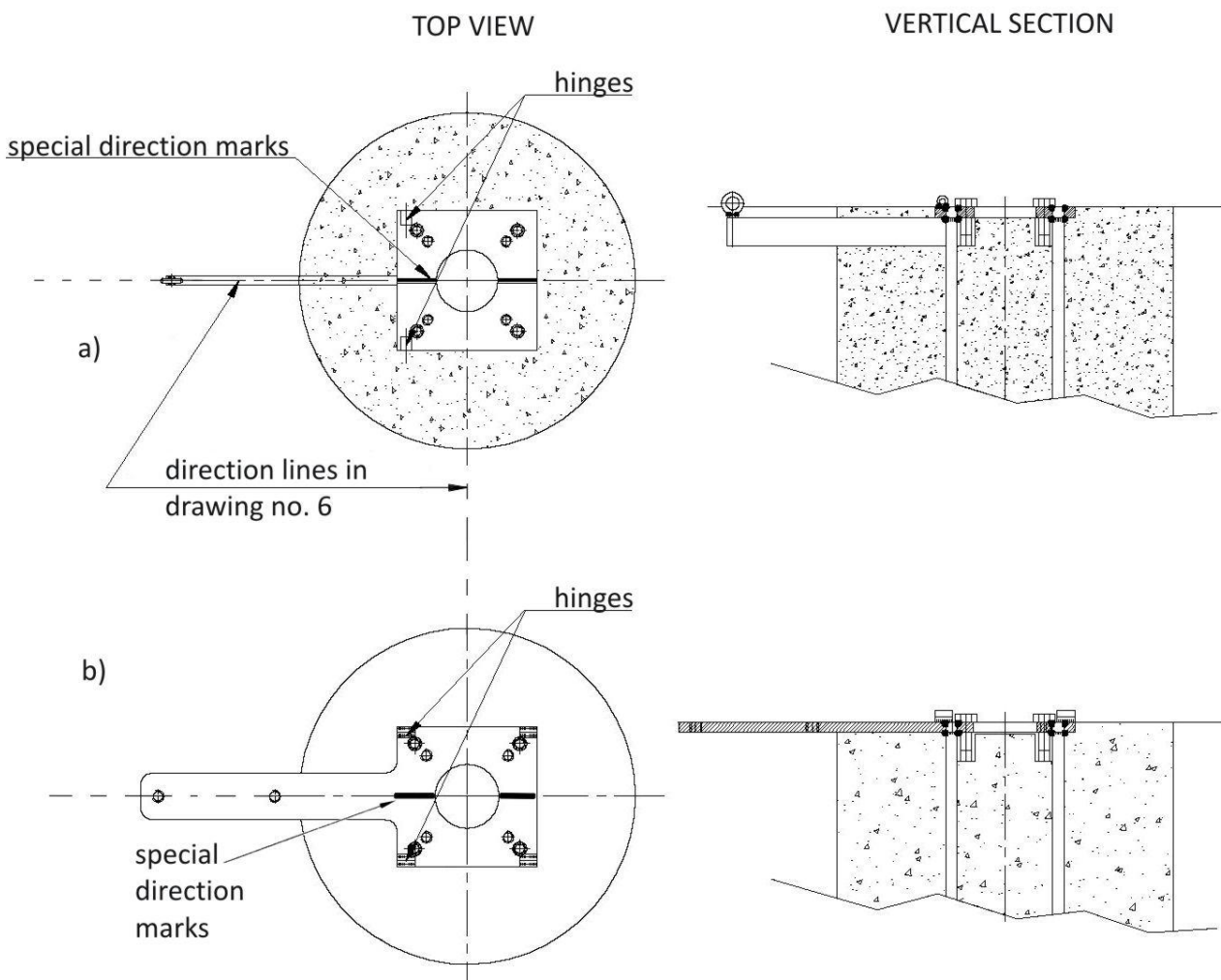

The anchors should be placed in the concrete of the class B20 quality or higher. Each time the anchor is put into the foundation the concrete should be mixed, so that it covers tightly the ribbed bars and there are no air chambers inside. During the concrete setting the foundations should be moistened (in the first week twice a day, in the second week once a day). You ought to wait minimum 2 weeks before you proceed with the installation of the pillars.

V. Pillars installation



WARNING! Failure to follow the sequence of these assembly operations could result in serious accident or damages to the cage construction.

The installation of rear and central pillars (item 3 and 4) on anchors (item 2) is done in the following way: we unpack delivered pillars, then we remove blocking screws (M 8x16) from the ratchet mechanisms and loosen steel lines, next the lines should be unwound a little and their ends ought to be temporarily fastened to pillars at the level of ratchet mechanisms (drawing no. 1 and 2), after that rear and central pillars should be installed one by one according to the sequence shown below:

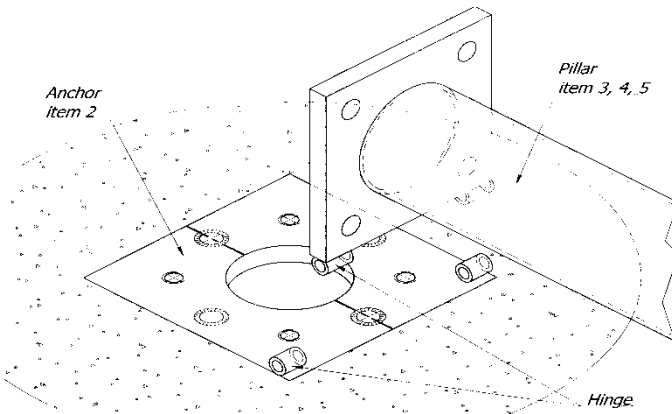

Stage one.

Position the pillar in the anchor hinges.

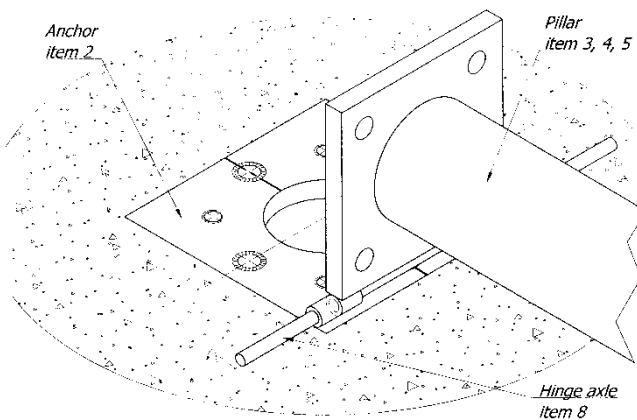

Stage two.

Slide hinge axle (item 8) into the anchor hinges.

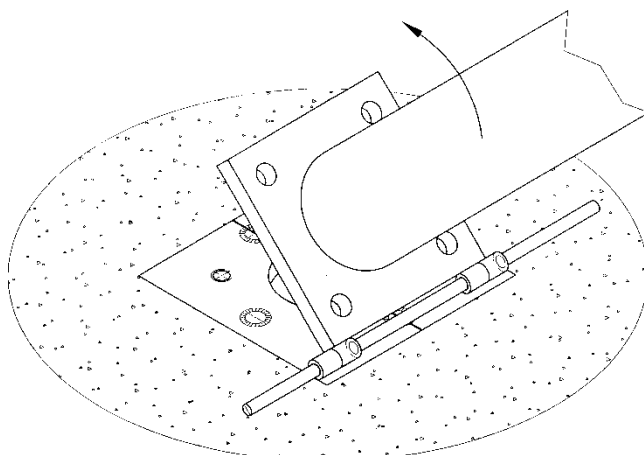

Stage three.

Lift the pillar to vertical position.

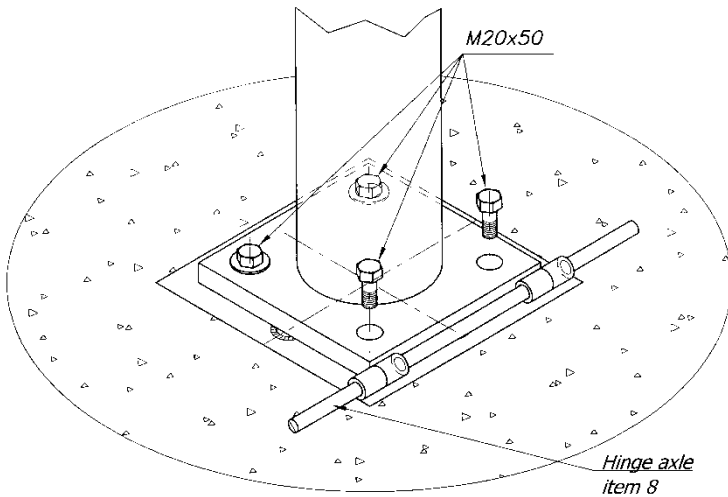

Stage four.

While one man is supporting the pillar in upright position, the other person is screwing it to the anchor in the following sequence:

- a) screw down two screws (M 20 x 50) opposite the anchor hinges,
- b) then screw down two remaining screws (M 20 x 50) next to the anchor hinges,
- c) remove hinge axle (item 8).

After the assembly of rear and central pillars we can start installing extreme pillars (item 5) and gate pillars (item 6). **All assembly operations of gate, gate cars and extreme pillars are executed before the whole gate construction is lifted to vertical position.** Extreme pillars should be raised together with gate doors in that way there is no need to use a crane or an extension arm, because we are not supposed to work at the height of 10 m. The assembly process is done as follows:

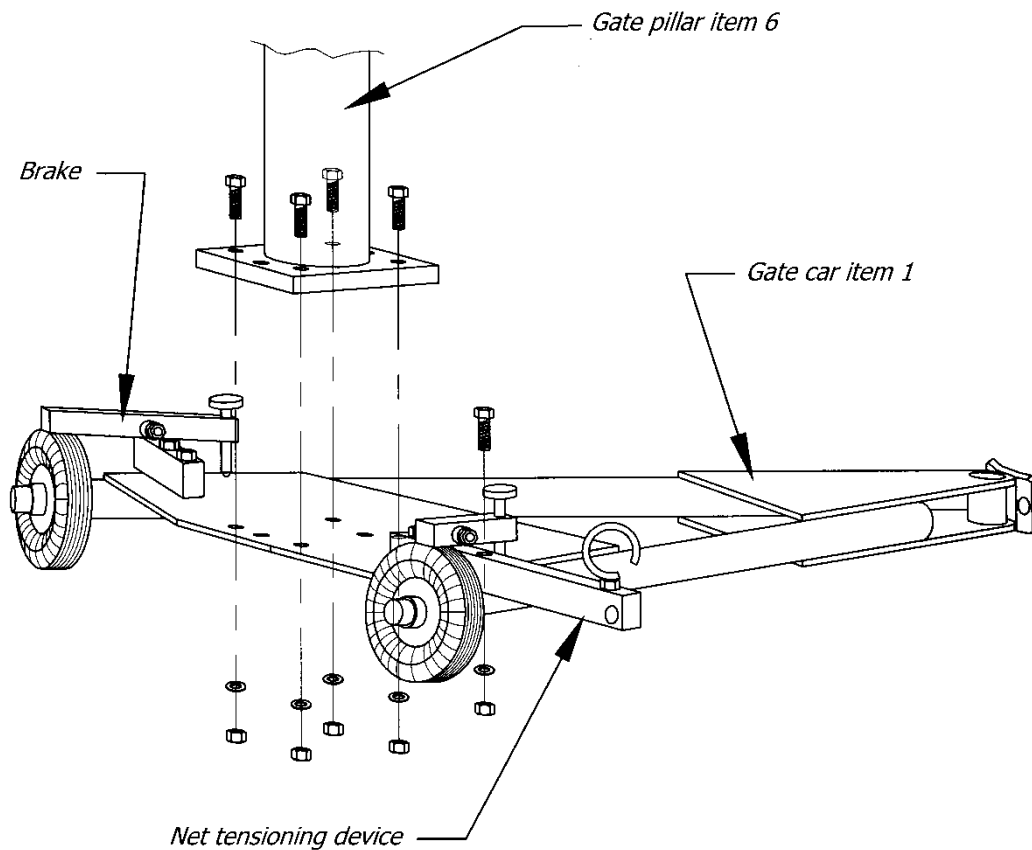

A. Unscrew net tensioning device situated in gate car (item 1) and install it in its working position as shown in the above picture. Screw gate pillar (item 6) to gate car (item 1) by means of four screws (M 20 x 60).

Gate pillar should be placed on gate car in such a way that the extension arm of gate pillar and the net tensioning device are lined up.

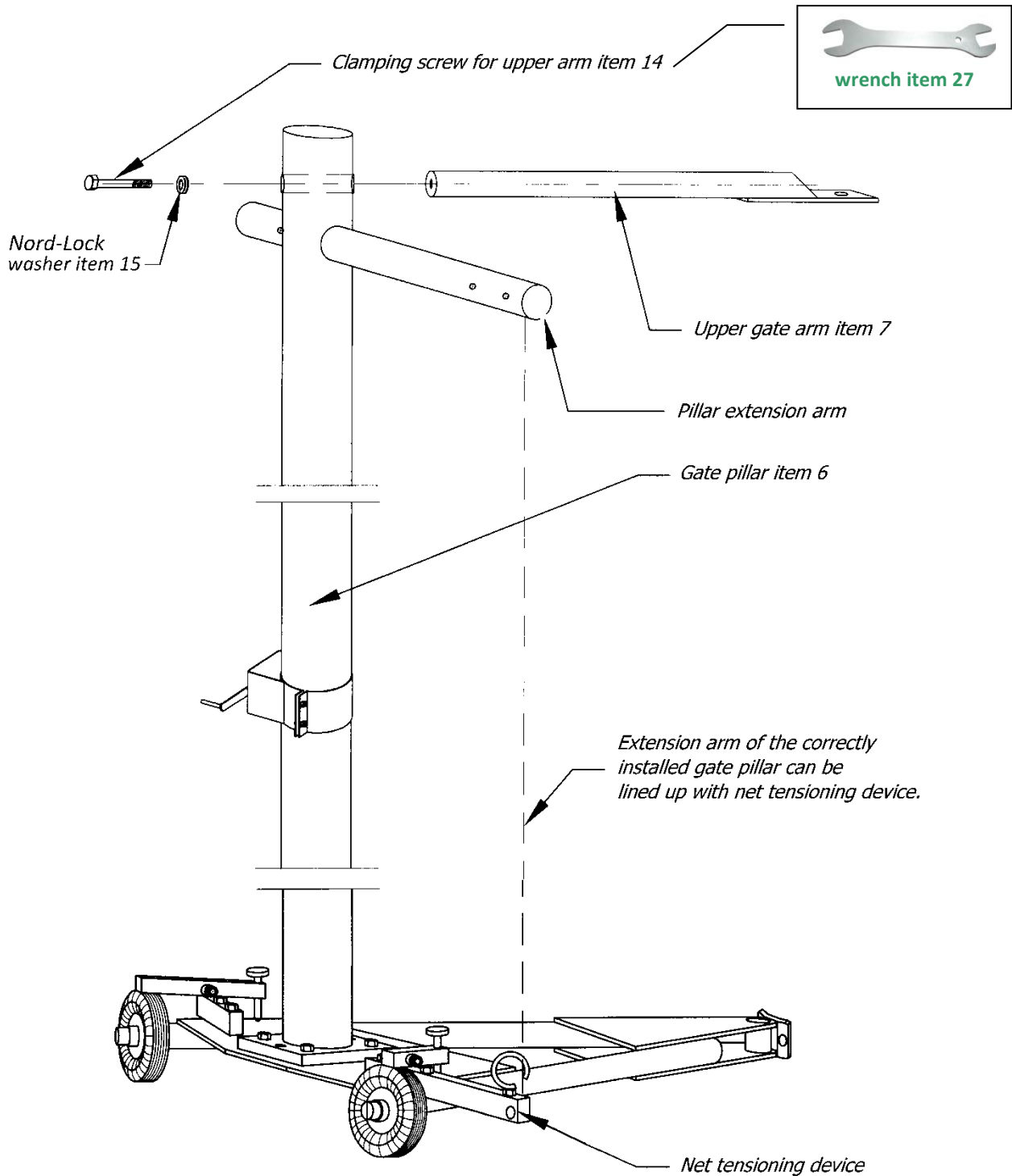

B. Install upper gate arm (item 7) at the top of gate pillar – according to the rotation axis of gate car (item 1). Use clamping screw M 20 x 160 (item 14), Nord-Lock blocking washer (item 15). Use the included metric wrench (item 27) to install the arm. **Attention! The clamping screw (item 14) should be scrupulously screwed down (until you feel resistance). The link between the upper gate arm (item 7) and the gate pillar (item 6) plays a significant part in the safety of the cage construction.**

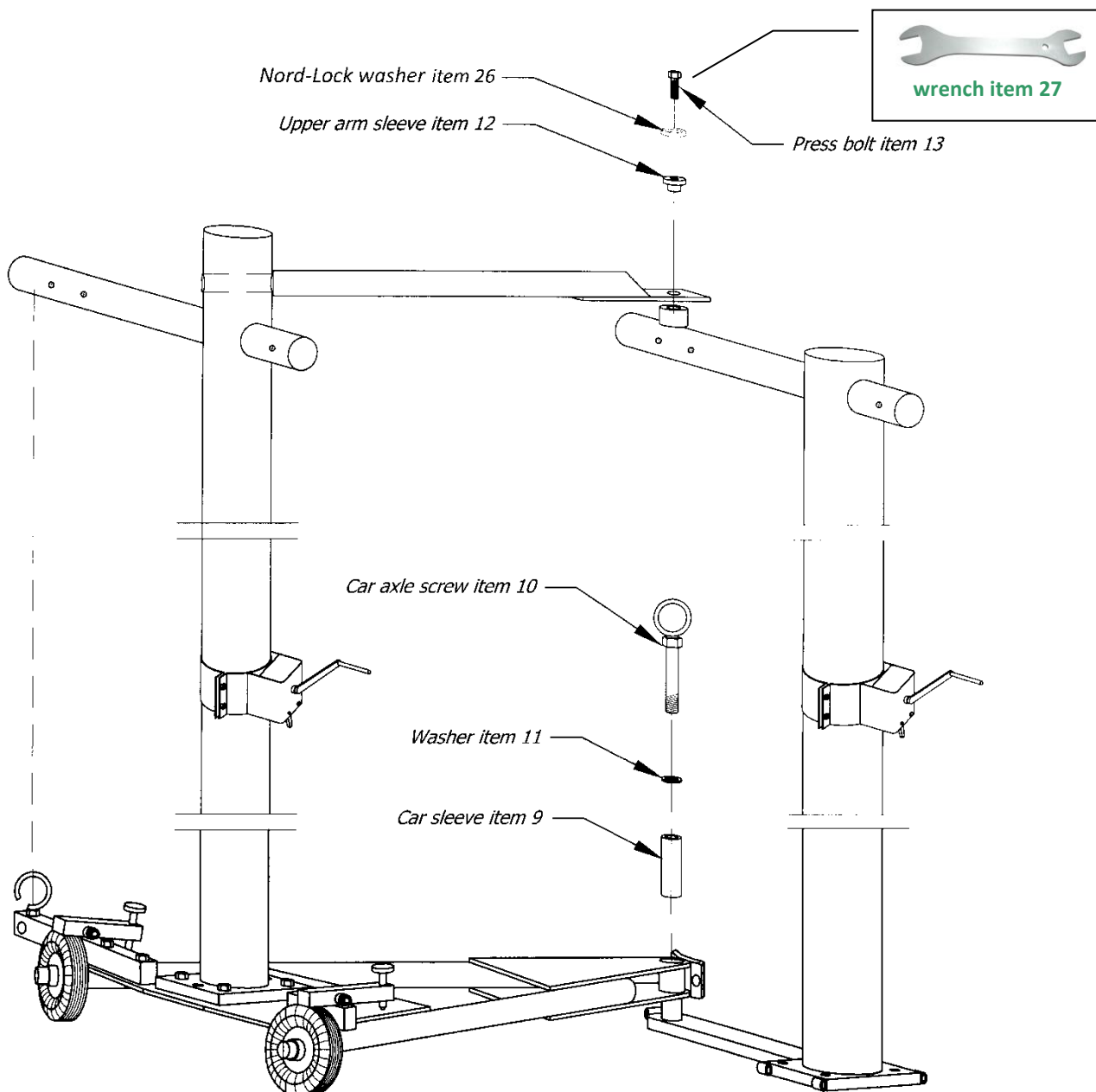

C. Connect extreme pillar (item 5) with the assembled gate, it is a rotational joint. Car gate is connected with the foot of extreme pillar by means of car axle screw M 20 x 120 (item 10), car sleeve $\varnothing 20 / \varnothing 30$ (item 9) and washer $\varnothing 20 / \varnothing 40 \times 3$ (item 11). Upper gate arm is linked with the extension arm of extreme pillar by means of press bolt M 16 x 40 (item 13), Nord-Lock blocking washer (item 26) and upper arm sleeve (item 12). Sleeves (item 12 and 9) have to be greased before installing. **Attention! The press bolt (item 13) should be scrupulously screwed down (until you feel resistance). The link between the upper gate arm (item 7) and the extreme pillar (item 5) plays a significant part in the safety of the cage construction.**

D. The assembled gate door is placed next to the anchor for extreme pillar. Then we put the foot of extreme pillar into the anchor hinges and slide in hinge axle (item 8) according to stage 1 and 2 of pillars installation (see Chapter V). Next we swivel gate car together with gate pillar around the rotation axis of the gate door to the angle of 90° . During that operation extreme pillar is resting on the ground. The wheels of gate car and whole gate pillar are being hold at the height of 2 m approx.

E. Now side cable arms (item 18) are to be installed, two for each gate pillar. The arms (item 18) are mounted at approx. 3 m and 6 m measured from gate car (item 1) – see the drawing on the next page. The points are labelled with blue belts on gate pillars. **At this stage you can also install cage pillar shields (OS290, OS296) and soft pads (OM-150), which are available as optional accessories. Please see the instruction manual of the shields for further information.**

F. That is the starting point of the last stage which is lifting the whole gate door to vertical position. **We recommend using a cage gate lift CGL-3 at that stage. CGL-3 is produced by Polanik and it is available as optional accessories. Please see the gate lift instruction manual for further information on lifting procedures.** When the gate door has been raised we can screw extreme pillar to its anchor according to step 3 and 4 of pillars installation (see Chapter V).

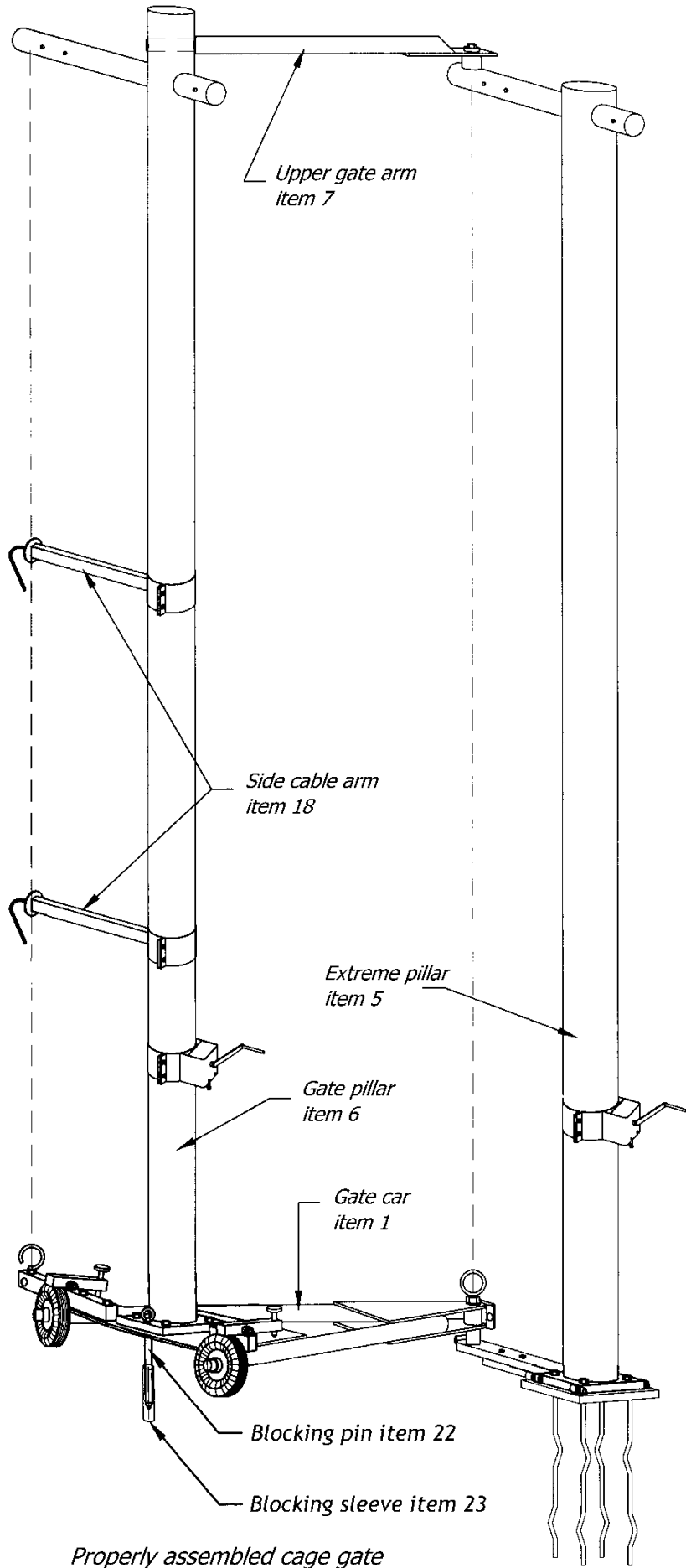

VI. Net hoisting

The installed pillars and gate doors constitute the main cage construction which is ready for installing and hoisting the net. Firstly bottom net tension cable (item 19) ought to be threaded through the eyelets which are located in the net straining arms of anchors (item 2), see the drawing on the next page. Cable regulating screw will help us to strain it. Next we do the same with two gate car cables (item 20).

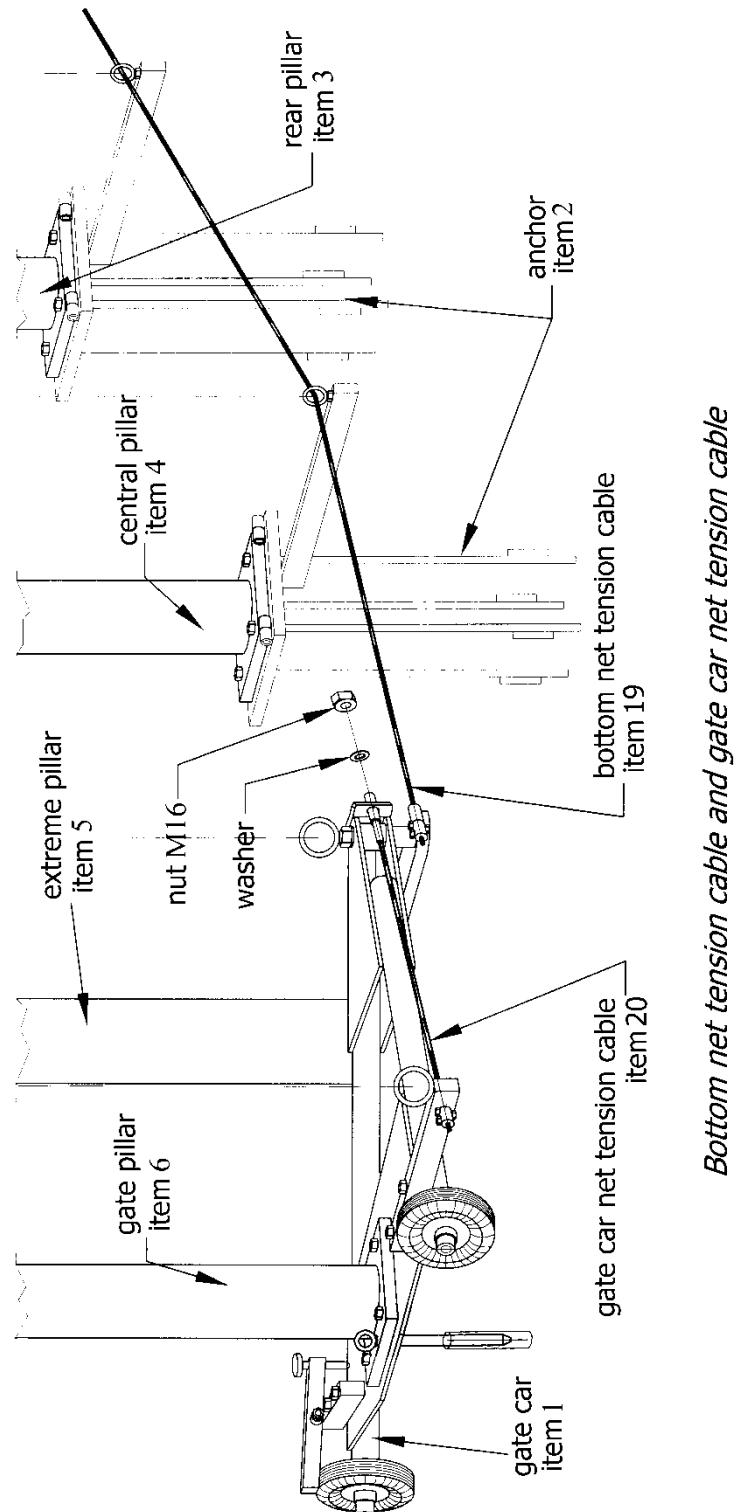

When we complete these preliminary works, the net can be laid down on its circumference according to drawing no. 5. Then we begin with attaching it to the steel ropes of the pillars by means of special catches. One end of each steel rope is fixed permanently to the bobbin of the ratchet mechanism and the other one, which has been temporarily fastened to pillar (see Chapter V), should be now untied and attached to the net. That operation is repeated at each pillar. Next edge steel cable of the gate panel (item 24) should be installed:

a) edge steel cables (item 24) are threaded through the net meshes near the side edges of the net,



b) one end of the steel cable (item 24) is to be linked to the snap hook of the gate pillar wire rope,



c) the bottom end of the edge steel cable (item 24) is fastened to the gate car.



Now we can hoist the net. The lifting of the net should be executed successively by approx. 2 m at each pillar and ought to be continued up to the maximum height apart from the gate pillars, at which the net must be lower than the maximum height by approx. 20 cm. **Do not lift the steel ropes of the pillars without the net – it may not be possible to lower them without the appropriate load.** Next the net is to be hooked onto the side arms (item 18):

a) auxiliary ropes which are attached to the net edge will help you to hook the net without a ladder,



b) two people manoeuvre the net edge into the side arm hook easily,



c) properly hooked net.

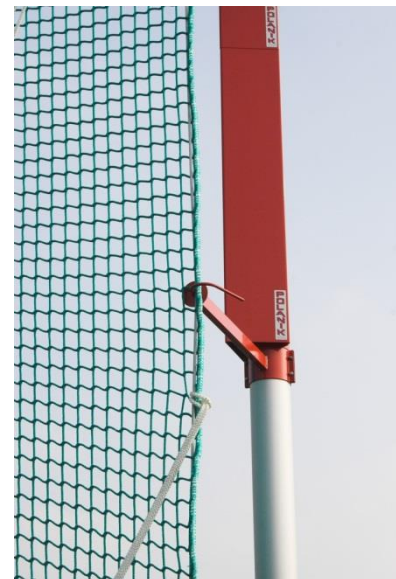

If the net is fastened at the both sides of the gate, you can raise the net at the gate pillars to the maximum height using the crank (item 16). The lower edge of the net should be folded under tension cable (item 19) and gate car cables (item 20), next we strain the net and fix the edge to the meshes with supplied hooks (item 21). **That way the net surface will not touch the aluminium elements of the cage construction in any point - it is extremely important for correct impact absorption and pillars' life.**



In order to provide proper net position (during strong winds the net may deflect from the required projection like a sail) horizontal stay ropes 1,6 m long (item 25) are supplied. The net is tied to each pillar (except for the gate pillars) at 2m from the ground. **Please make sure that the rope loops around the pillars are loose enough to provide easy sliding. That allows you to lower the net smoothly to its idle position – max. 1/3 of its height, which is recommended for breaks in competitions or training periods, especially during strong winds.**

VII. Final adjusting

- When the cage construction is mounted and the net is raised, the blocking sleeves (item 23) should be installed in the concrete paths. Please position the holes for the sleeves according to drawing no. 6. The sleeves enable you to secure the gate doors with the blocking pins (item no. 22) at two points: 112 cm from the cage axis and 891 cm from the circle centre (see drawing no. 5), and consequently to narrow the danger sector.
- The ratchet mechanisms of the pillars should be blocked with screws (M 8 x 20) or padlocks. That secures the net against accidental loosening.
- Each gate car is equipped with a brake. After positioning the gate doors the brakes ought to be tightened up.
- The cage is ready for use provided that the above operations are completed.

VIII. Maintenance and periodical inspection

As the producer we have done our best to make the cage guarantee maximum safety level, be easily operated and reliable in use. However the cage like any other pieces of sports equipment requires periodical inspections and must be used according to the instruction manual, the IAAF rules and operated by authorized personnel.

To keep the cage in good condition, the following maintenance operations and periodical inspections should be executed after every athletic season:

- Check the tensile strength of the net (use the samples) according to the IAAF instructions.
- Clean and grease the steel lines of the cage pillars.
- Grease the press bolt of the gate car brakes.
- Grease the sleeves of the gate cars.
- Remove the cranks. Keep them in safe place for future use.
- Fold the net provided it is dry and tie it. Keep it in safe place.
- The steel lines should be always secured and strained when the net is taken off. It prevents the steel lines from hitting the anodized aluminium surfaces of the pillars.
- Do not lift the steel lines of the pillars without the net – it may not be possible to lower them if they are not loaded.
- **During idle periods the net must be absolutely lowered. Lift the net only for using.**
- **In case of strong winds, during which competition throwing events (see the IAAF rules) and training meetings cannot be conducted, the net must be absolutely lowered.**
- **During idle periods, when the net is not dismantled for storage, the gate doors must be closed, blocked with blocking pins (item 22, draw. no. 3,6 and 8), the gate car brakes must be tightened. Additionally the gate doors should be secured with rope (min. rope diameter 16 mm).**

Even the best technical solutions cannot substitute for common sense. Hammer and discus throwing should be taken place under the supervision of qualified trainers. The producer shall not be liable for any incidents caused by improper cage assembly or its misuse.

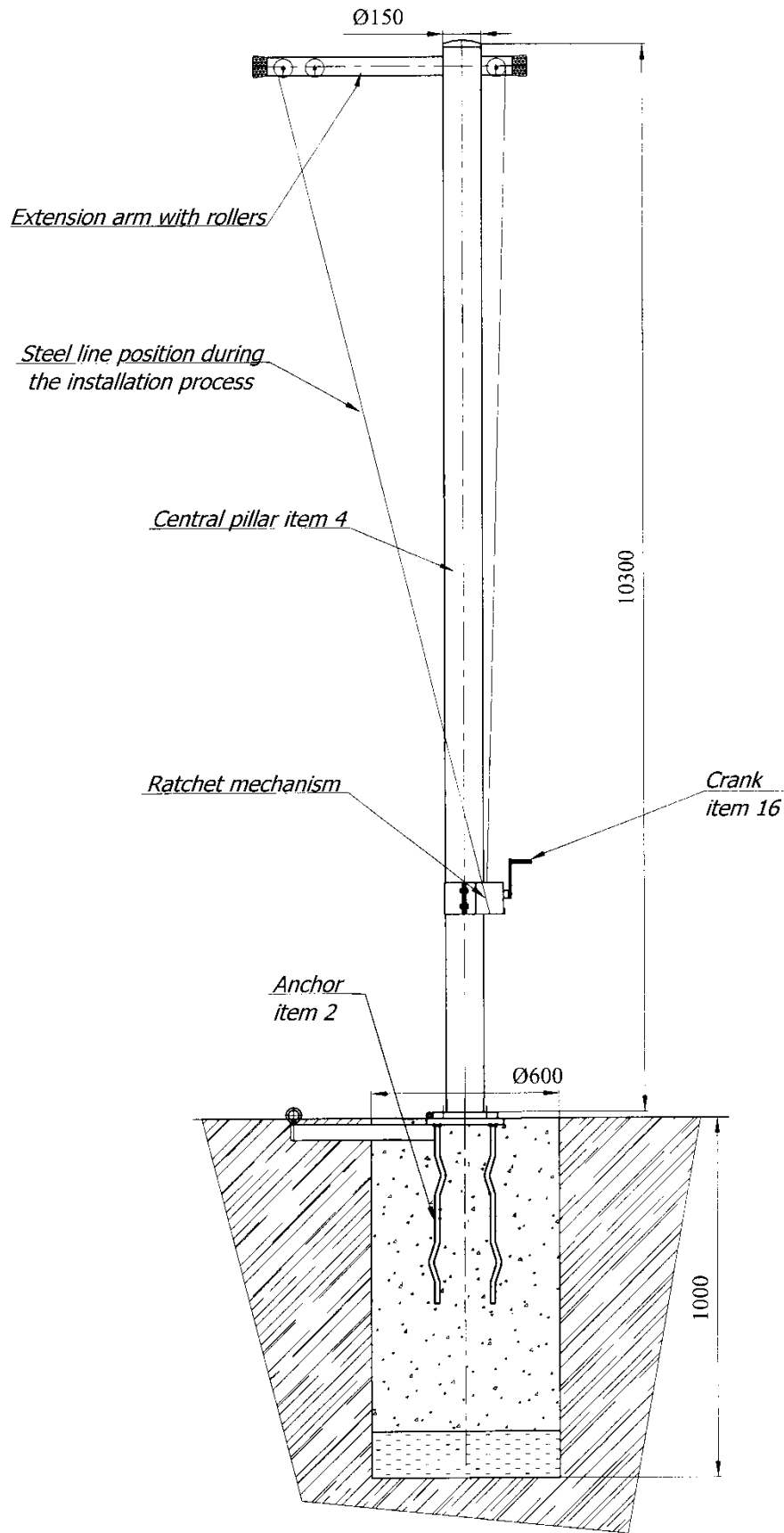

Central pillar
 Drawing no. 1

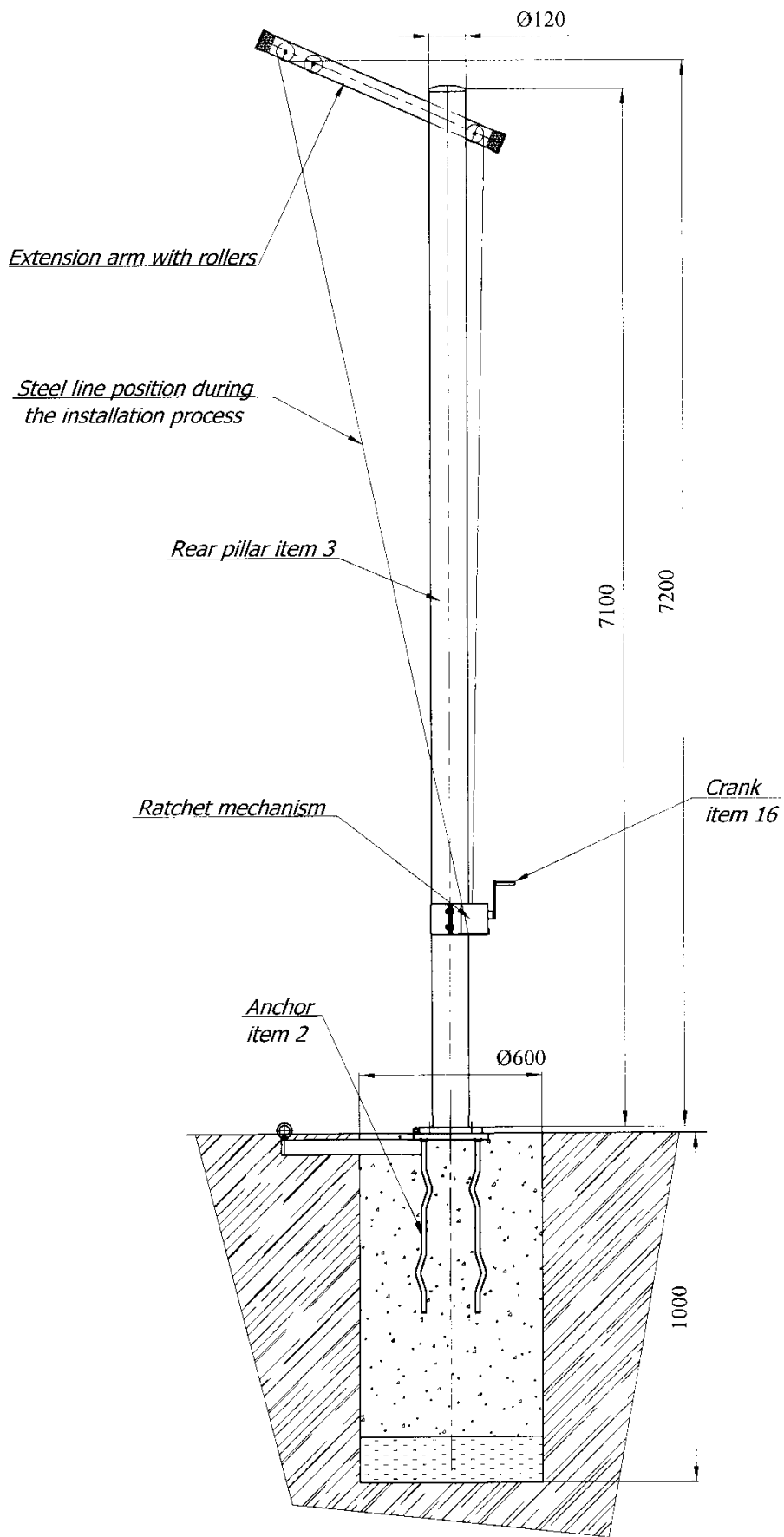

Rear pillar
Drawing no. 2

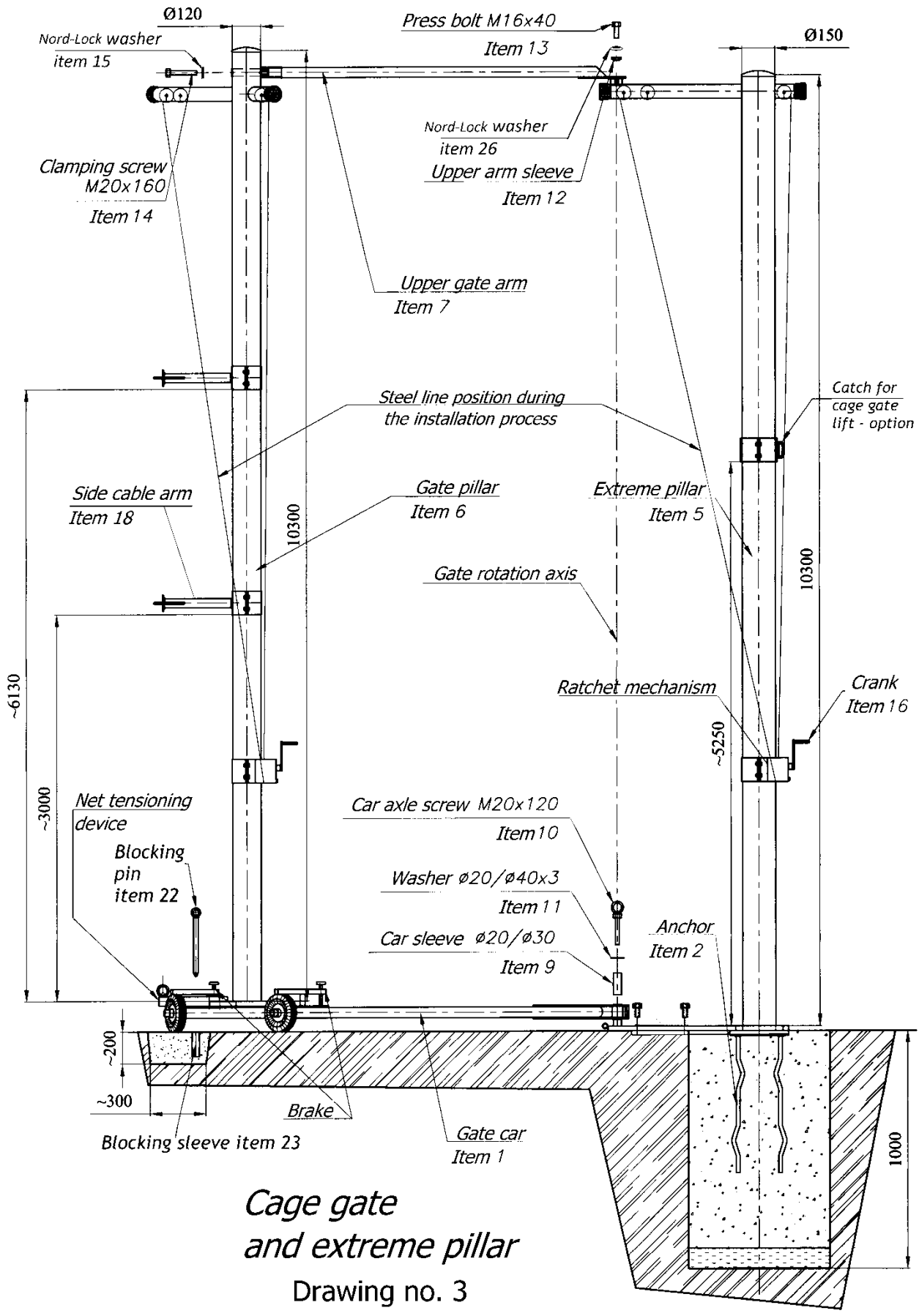

**Cage gate
 and extreme pillar**
 Drawing no. 3

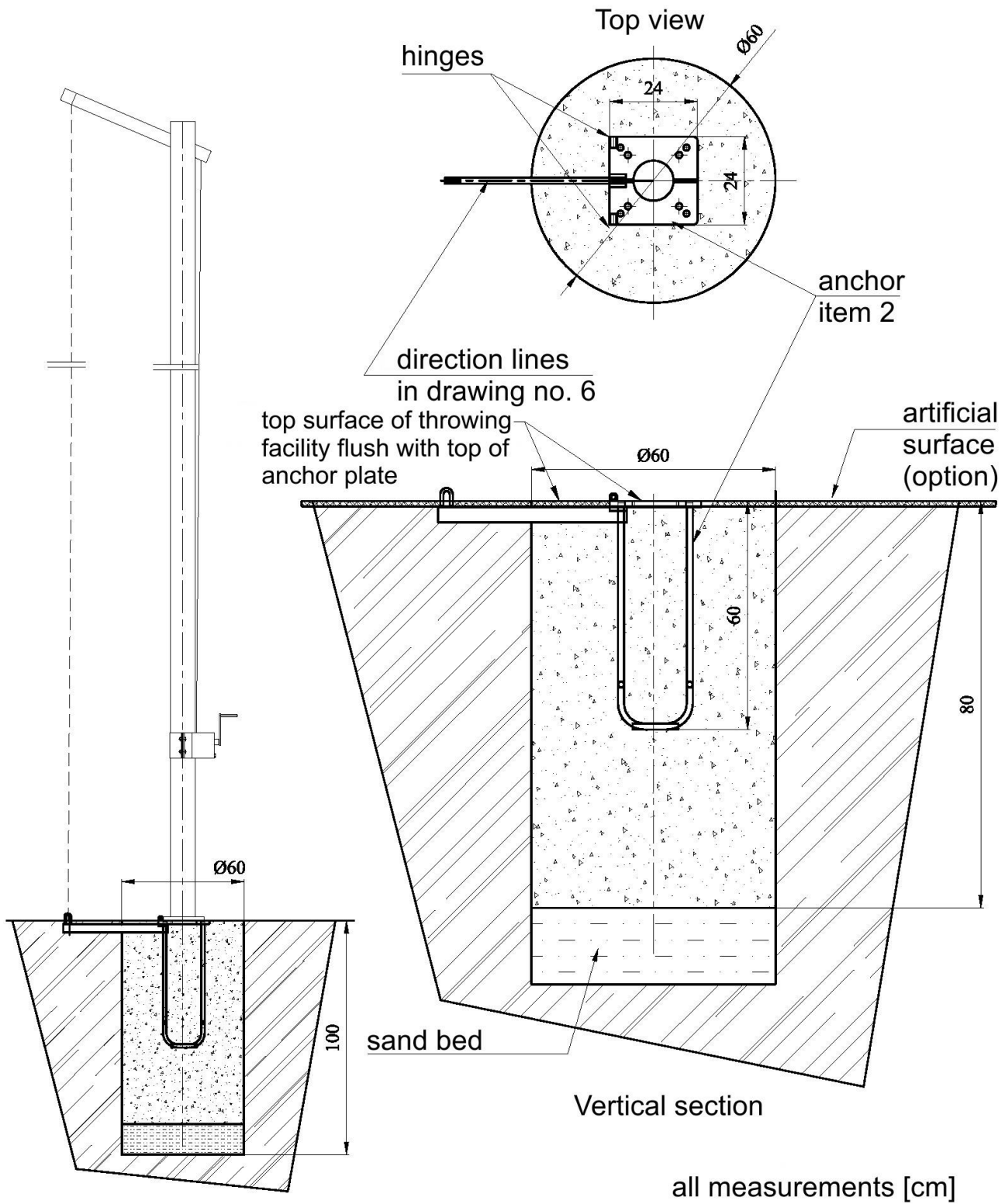

Foundation block of cage pillar (8 pcs)

Drawing no. 4a

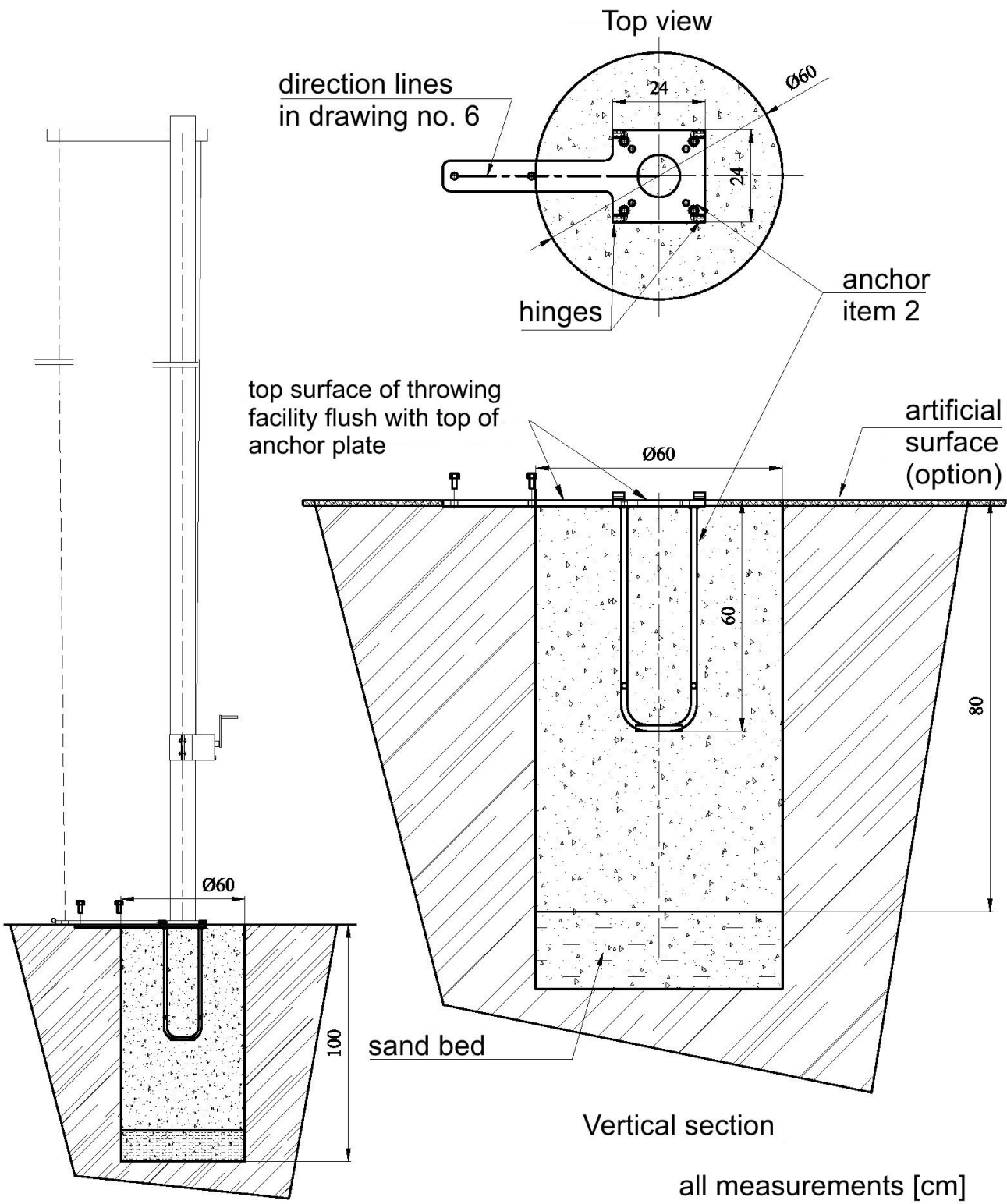

Foundation block of cage extreme pillar (2 pcs)

Drawing no. 4b

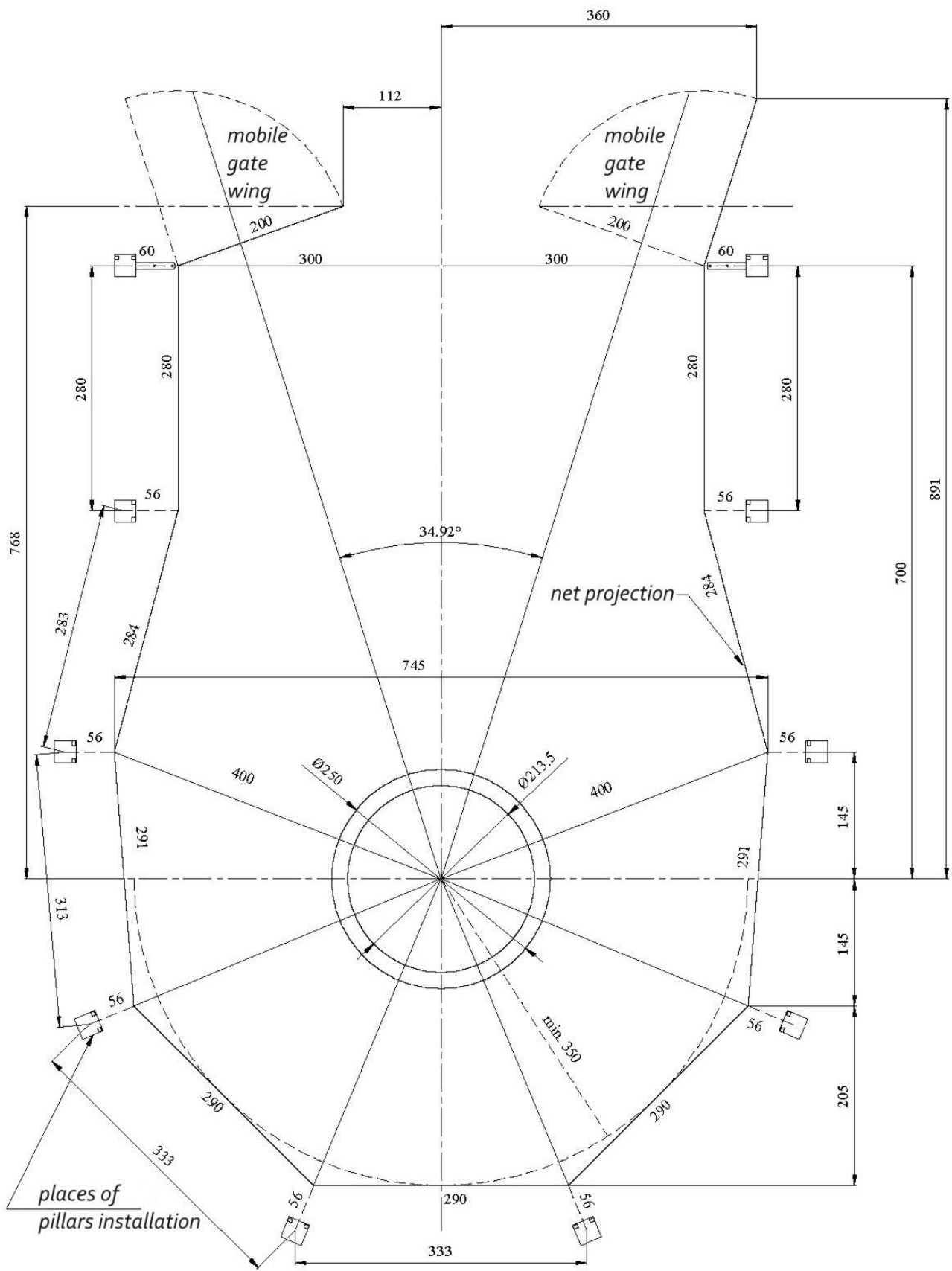

All measurements in [cm]

**Plan of the cage
Drawing no. 5**

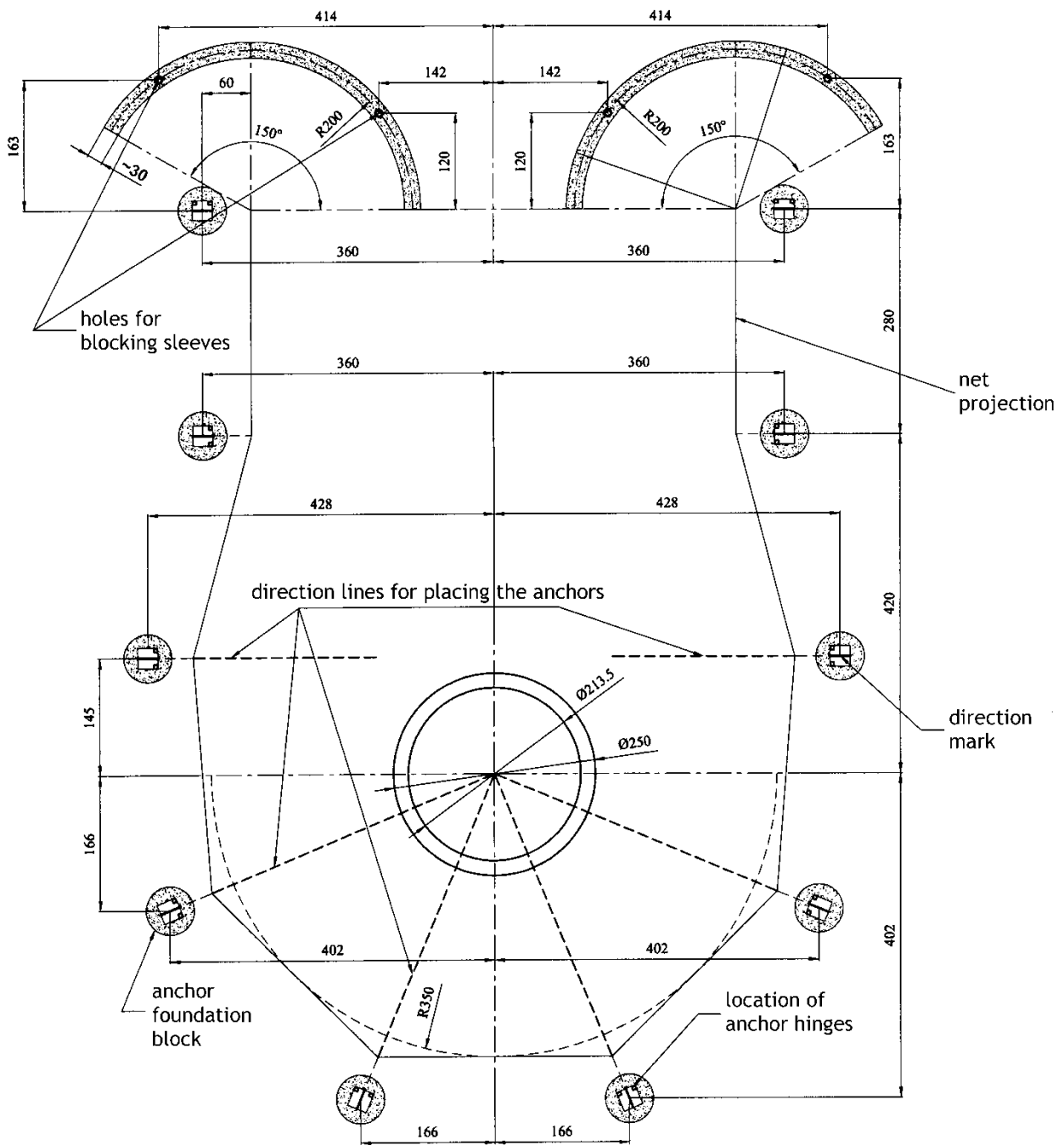

VERY IMPORTANT!

We recommend that you should consult the way of placing anchors in concrete blocks and making paths for gate car wheels with geodesy expert in order to ensure that anchors and paths are correctly levelled, spaced and positioned according to the direction lines.

All measurements in [cm]

The foundation blocks for the cage pillars

Drawing no. 6

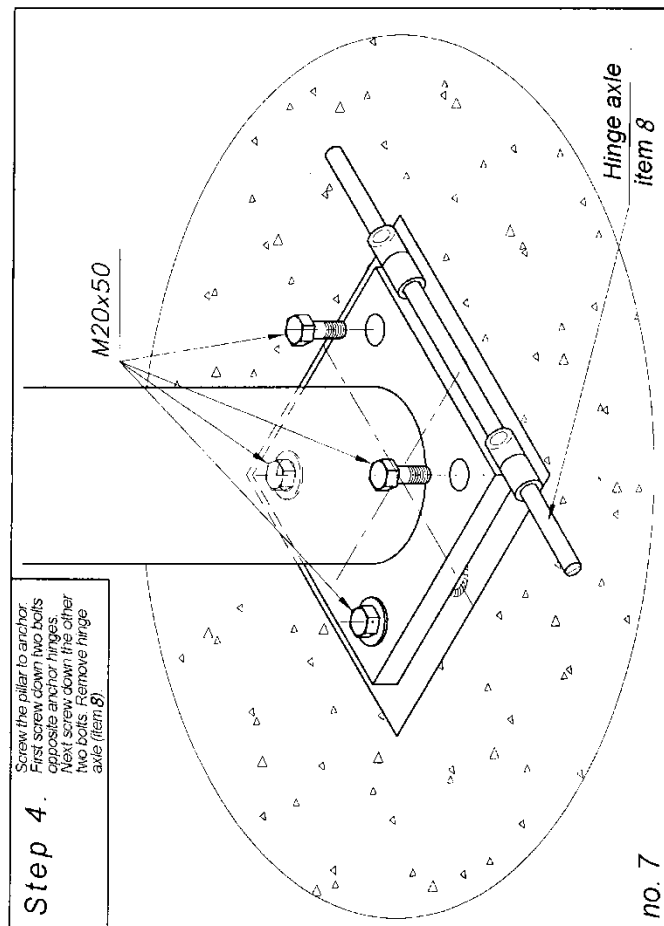
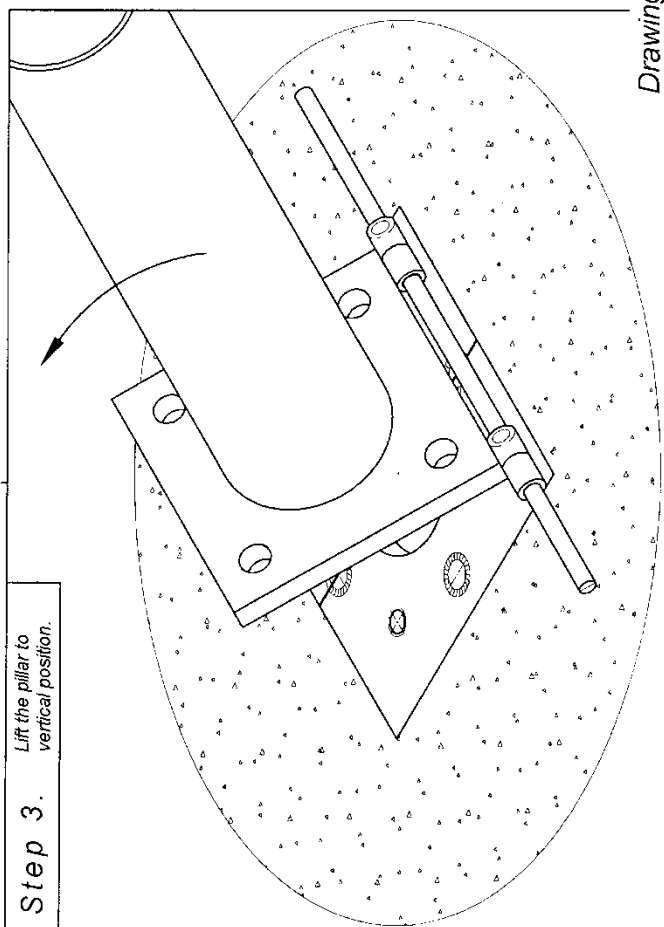
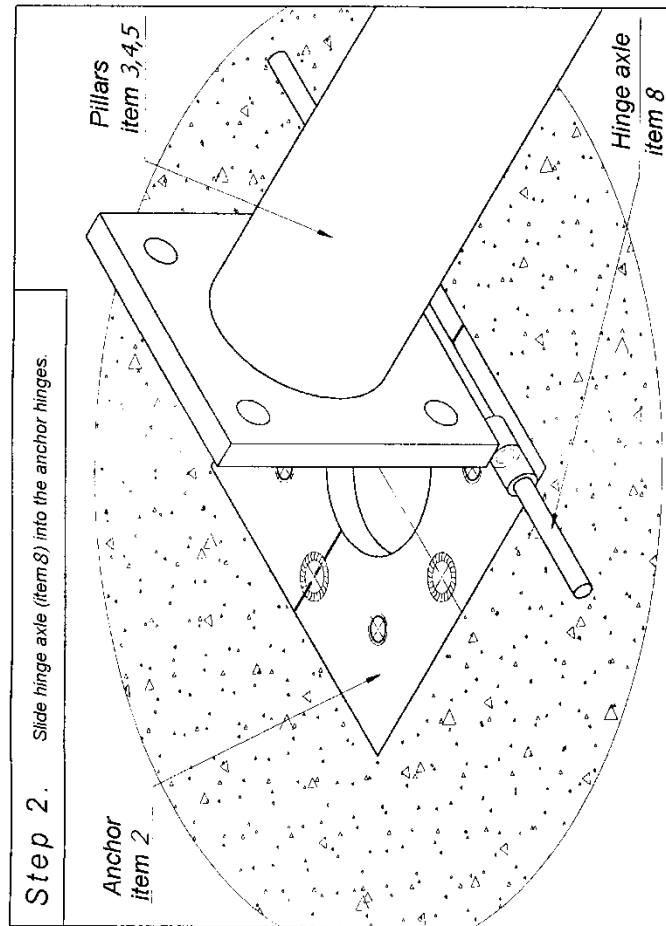
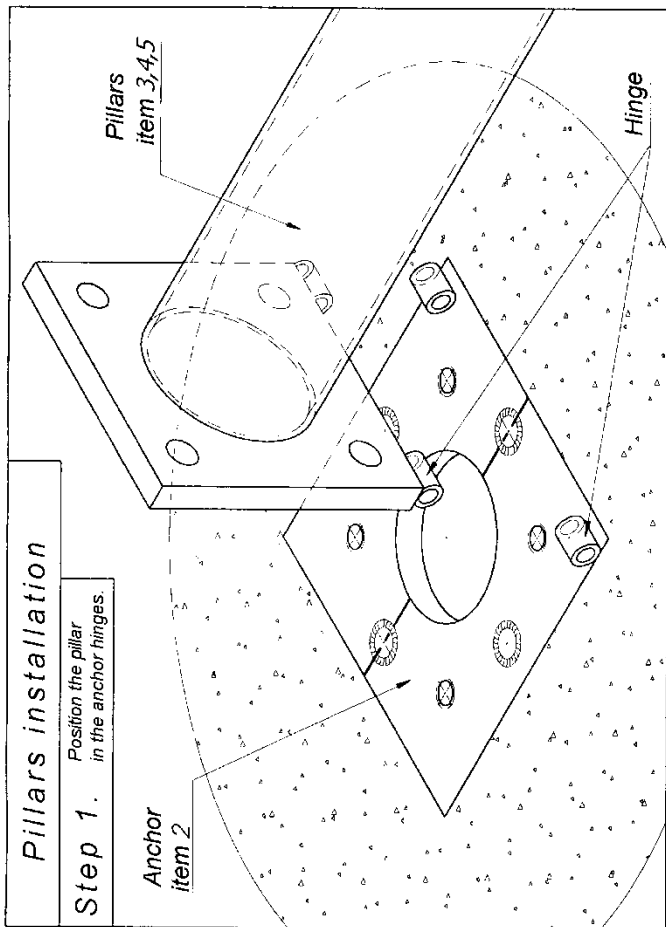

Drawing no. 7

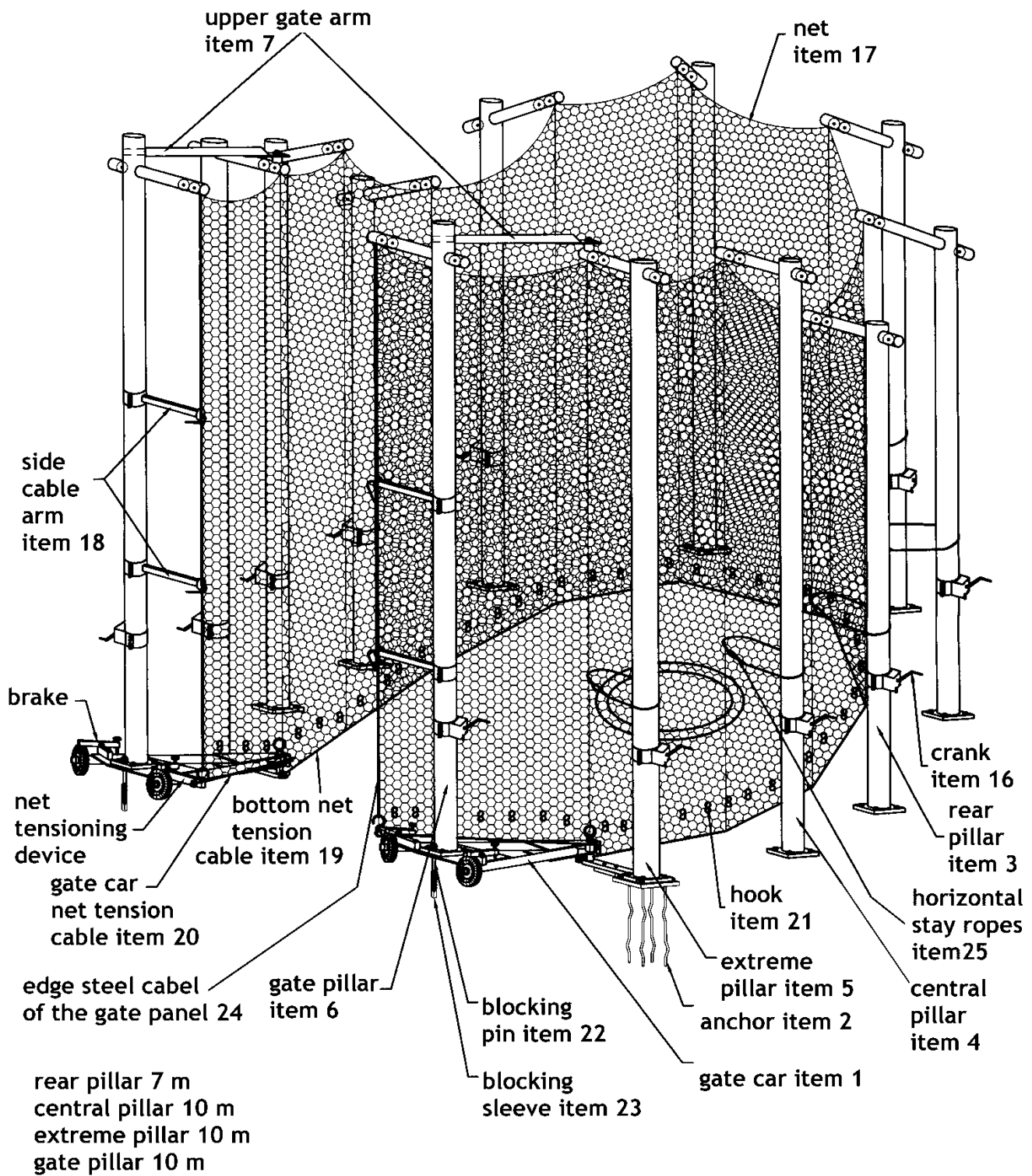

IAAF certificate no. E-00-0264

View of the mounted cage

Drawing no. 8

X. How to play the attached instructional video

The enclosed instructional CD can be viewed on VCD/DVD players and PC or MAC computers. If it does not start automatically, please explore CD main directory and click the file with .exe extension.

Minimal hardware requirements:

PC

P166 MMX, 32 MB RAM, CD-ROM, VIDEO CARD
WINDOWS 9x, NT 4.0, 2000, WINDOWS MEDIA PLAYER

MAC

QUICK TIME PLAYER WITH QUICK TIME MPEG EXTENSION

You can also find on CD:

-IAAF certificate (in .jpg format)

-a copy of this assembly manual (in .pdf format – requires Acrobat Reader).

International Association of Athletics Federations



Product Certificate

The IAAF is pleased to certify hereby that the following product:

Product's Trade Name: Throwing cage, Discus & Hammer

Description, Colour / Absolute Thickness: Aluminium, concentric circles, -

Company Name, Country: Polanik Sp. z o. o. - Sp. K., POL

Catalogue Number: KLM-7/10-A

IAAF Certification Number: E-00-0264

meets the dimensional requirements for use in all international athletics competitions.

It is for the purchaser to determine the item's fitness for the purpose based on his knowledge of the local conditions and use.

Valid from: 1 July 2016

Until the last day of: July 2020

This certificate is issued in accordance with the terms and conditions of the IAAF Certification System of track and field facilities, implements and competition equipment.

SEBASTIAN COE
IAAF President

JORGE SALCEDO
IAAF Technical Committee Chairman

