

POLANIK
Poland, Życzliwa 11
97-300 Piotrków Trybunalski

tel. +48 44 646 44 81
tel. +48 44 648 50 89
fax +48 44 646 43 58

e-mail: info@polanik.com
www.polanik.com



TECHNICAL SPECIFICATION **INSTRUCTION MANUAL**

Training hurdle

PP-174/7

PP-174

PP-175

PP-185

PP-185/4



File: 2015-03-12

PRODUCT SUPPORT

Paweł Ciechanowski

p.ciechanowski@polanik.com

Contents

Chapter	Page
I. General description and use	2
II. Technical specification	3
III. Parts list	4
IV. Assembly	4
V. Operation and maintenance	5
VI. Packing and transport	5
VII. Product images	6
VIII. Declaration	7

I. General description and use

The steel-aluminium training hurdles (PP-174/7, PP-174, PP-175, PP-185 and PP-185/4) are pieces of athletics equipment and are designed for training hurdle races, for juniors and seniors in sports schools and clubs. The main advantages of the hurdles:

- cost-effective construction
- very wide range of heights (especially PP-174/7)
- strong and durable frame made of galvanized steel
- simple and reliable height adjustment system
- stainless powder painted aluminium telescope tubes
- plastic durable top board ribbed construction, resistible to weather conditions
- collapsible construction lowers transport costs.

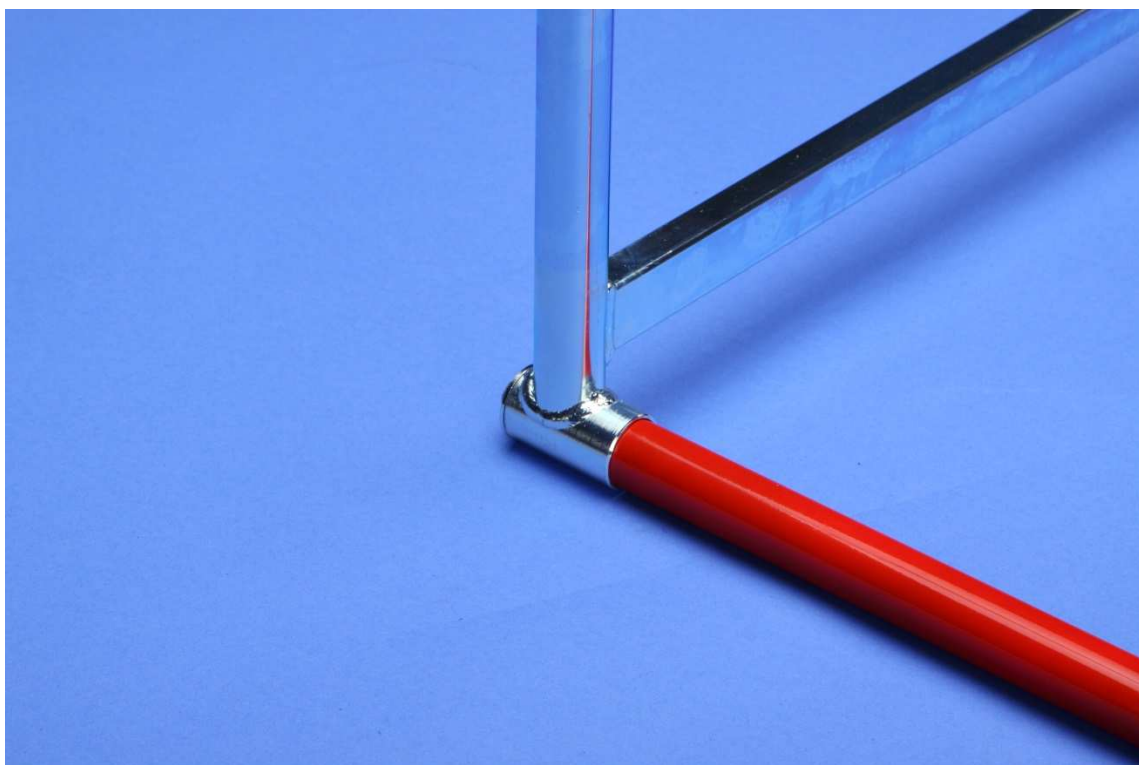

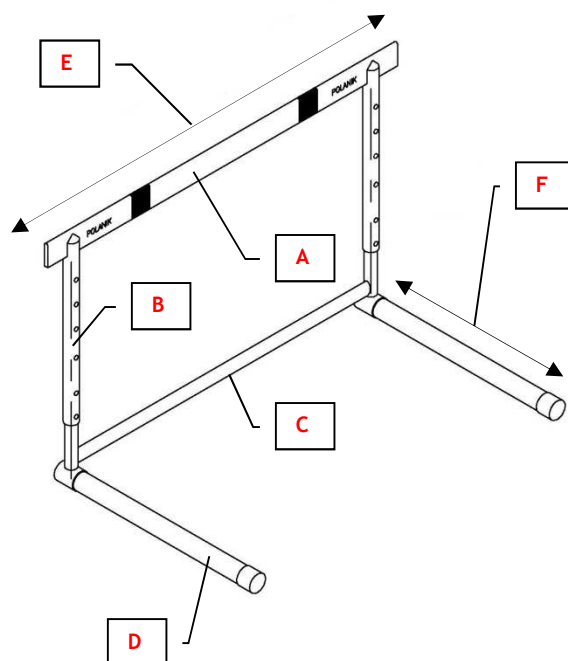

II. Technical specification

Code	PP-174/7	PP-174	PP-175	PP-185	PP-185/4
Hurdle type	training, collapsible				
(A) Top board	plastic, with inside ribbing				
(B) Telescope tube	aluminium powder painted, spring-loaded button system of height adjustment				
(C) Frame	steel, galvanized				
(D) Feet	steel powder painted, permanently fixed counterweights				
Heights [mm]	-	-	-	500	500
	-	-	600	600	600
	650	-	-	-	-
	-	-	-	-	675
	686	686	686	-	-
	762	762	762	762	762
	838	838	838	-	-
	914	914	914	-	-
	991	991	-	-	-
1067	1067	-	-	-	
(E) Top board length [mm]	1150	1150	1150	1150	1150
(F) Foot length [mm]	610	610	610	610	610
Net weight [kg]	5,5	5,5	4,4	4,2	4,2

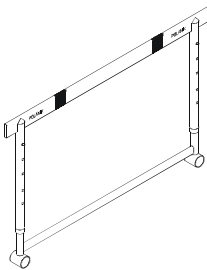
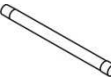

III. Parts list (part sets)

The hurdle is delivered in parts and one complete hurdle contains:

Item	Part/set description	Q-ty pcs	Sketch
1	Hurdle frame	1	
2	Hurdle foot	2	
3	Washer	2	
4	Foot screw	2	

IV. Assembly

Foot screws (item 4) with washers (item 3) are temporarily screwed into hurdle feet for transport (or they can be found in a separate box when big quantities of the hurdles are delivered). A metric wrench no. 13 is needed to perform the assembly. Although one person can prepare the hurdle for use, a convenient and fast assembly process requires two persons.

To assemble the hurdle please do the following:

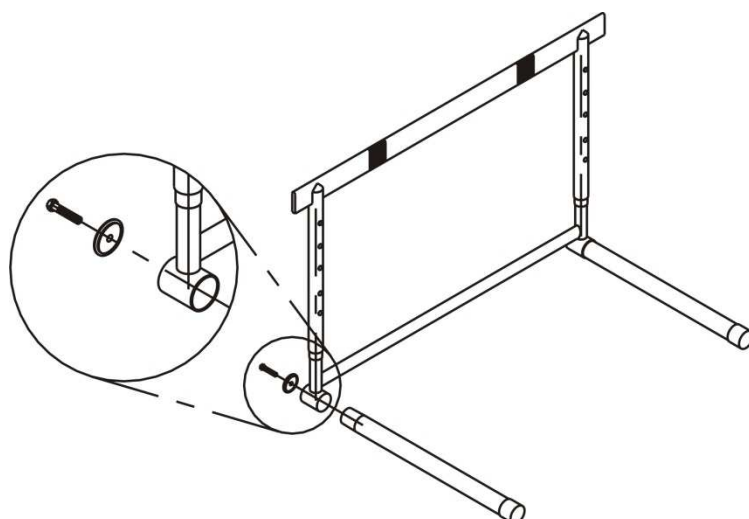

- slide carefully one hurdle foot (item 2) into one socket of the frame (item 1),
- make sure the foot (item 2) is properly placed in the socket, if it is not straight, please correct its position,
- screw the foot (item 2) to the hurdle frame (item 1) by means of the foot screw (item 4) and the washer (item 3),
- install the other foot in the same way.

The main goal of the hurdle collapsible construction is to assure easy and cheap transport. Please note that once you screw the feet down, the hurdle is practically non-dismountable. Therefore we do not recommend unscrewing the hurdle feet during idle periods. Removing the feet without proper tools can cause serious hurdle damages.

V. Operation and maintenance

During idle periods the hurdles must be stored in a roofed dry place. For optimal performance they should be stored and transported on Polanik hurdle cart: S-259. After every athletics season the hurdles must be cleaned from sand (mud, dust and etc).

VI. Packing and transport

The hurdles are put on pallets in parts (frames and feet separately) and wrapped with foil.



Package type		foiled pallet
Dim. [cm]	contents	30 pcs
	length	120
	width	80
	height	90
Volume m ³		0,86
Gross weight [kg]		~190

frames with telescope tubes and top boards mounted

box with hurdle feet

box with foot screws

VII. Product images

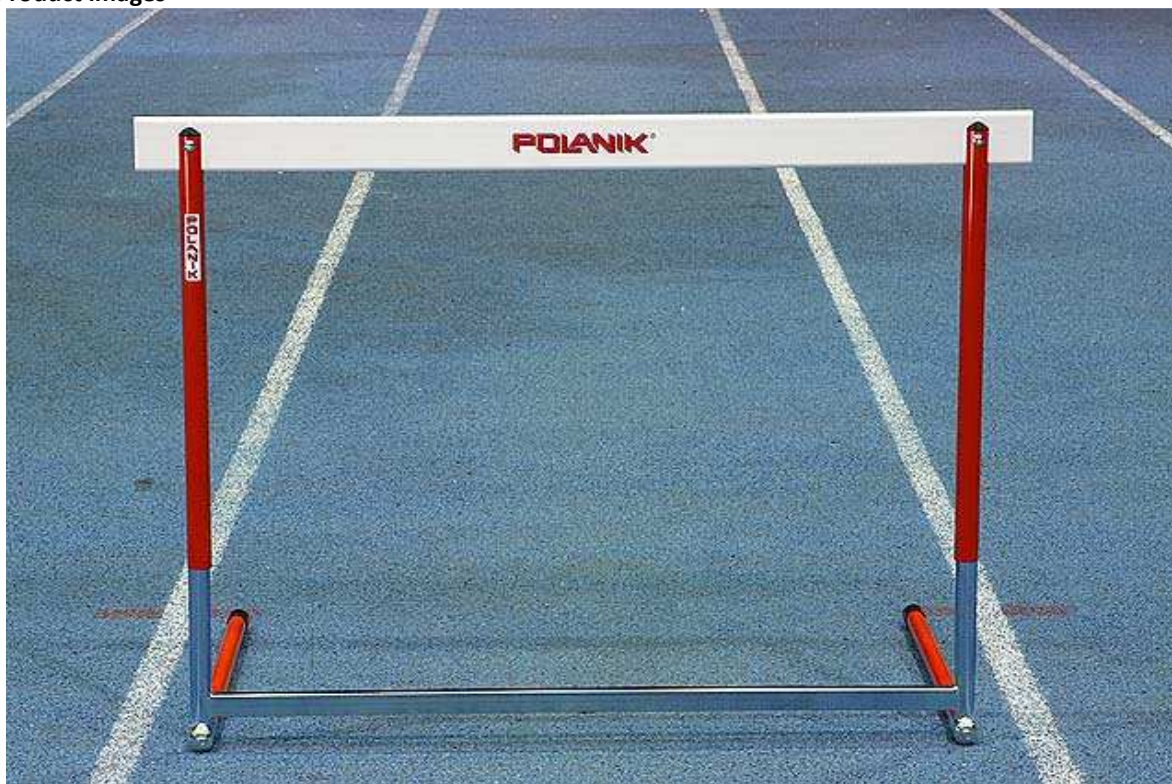

PP-174/7, PP-174, PP-175, PP-185, PP-185/4 © 2015 Polanik

The producer reserves the right to introduce without warning changes in product constructions and colours.

VIII. Declaration

1) No. 2015-03-12

2) Issuer's name: POLANIK

Issuer's address: Życzliwa 11, 97-300 Piotrkow Tryb.

3) Object of declaration:

No.	Description of goods	Code
1	Training aluminium hurdle, collapsible, height range 650-1067 mm	PP-174/7
2	Training aluminium hurdle, collapsible, height range 686-1067 mm	PP-174
3	Training aluminium hurdle, collapsible, height range 600-914 mm	PP-175
4	Training aluminium hurdle, collapsible, height range 500-762 mm	PP-185
5	Training aluminium hurdle, collapsible, height range 500-762 mm	PP-185/4

4) The object of declaration described above is in conformity with the requirements of the following documents:

Articles	Document title	Issuer
Rule 168 points 2, 4	IAAF Competition Rules 2012-2013	International Association of Athletics Federations 17, rue Princesse Florestine BP 359 – MC 98007 Monaco Cedex Tel. +3377 93 10 88 88 Fax +377 93 15 95 15 www.iaaf.org

Additional Information

5) Declaration for:

Buyer/Distributor/User

Signed for and in behalf of:

POLANIK

2015-03-12 Piotrkow Tryb.
(Date and place of issue)

6) Pawel Ciechanowski
Product Manager

.....
(Name, function)



.....
(Signature or equivalent authorized by the issuer)