

## ASSEMBLY MANUAL

### Training hammer and discus throwing cages

**KLM-5/7-A**

**KLM-7/9-A**

**and ground anchor set K6-0027**



Thank you for purchasing POLANIK cage type KLM-7/9-A (KLM-5/7-A) and anchor set K6-0027

### Safe assembly and use

- Before you start to assemble and use the cage please read this manual carefully, watch the enclosed instruction film and store the manual in a safe place for further reference. Polanik Sp. z o. o. shall not be liable for any cage damages which are the result of the failure to follow this manual.
- Unauthorized copying of this manual, in whole or in part, is prohibited.
- The contents of this manual are subject to change without notice.
- Warning! The sports equipment produced by Polanik Sp. z o. o. is designed for athletics training and use in sports competitions only. Please pay special attention especially when using throwing implements and other throwing equipment, misuse of athletics equipment and implements can cause serious injury or in extreme cases even death. That is why training and use during sports events have to be always supervised by authorized sports personnel. In no event shall Polanik Sp. z o. o. be liable for any special, incidental, indirect or consequential damages in connection with the purchase or use of POLANIK products or costs over the original cost of the product.
- Specific warranty terms:
  - 1) The use of the throwing cage (KLM-7/9-A (KLM-5/7-A)) is to be done in the properly marked and secured sports facility designed for that purpose and under supervision of qualified coaches, and according to: the rules of the International Association of Athletics Federations (IAAF), respective national athletics federation and local safety regulations. Failure to follow the above restrictions results in loss of the warranty rights.
  - 2) The throwing cage (KLM-7/9-A (KLM-5/7-A)) is designed to protect the spectators against the improperly released hammer (discus) which misses the cage mouth. The execution of that task brings a risk of damages to the cage elements (for example the pillars), as a crumple zone of an automobile is damaged to absorb energy from the impact during an accident to save passengers. The damages caused by the proper cage operation, which is stopping improperly thrown hammers (discuses) from flying outside the cage and absorbing the impact energy in order to protect the thrower inside the throwing circle, are recognized as a normal wear of the product and are excluded from the warranty. The damages can be removed in course of payable repair or replacement of the cage elements.
  - 3) **The use of the non-genuine spare parts (not produced by Polanik) results in loss of the warranty rights.**

## Contents

Chapters	Page
Safe assembly and use	2
I. Characteristics of the hammer/discus safety cage KLM-7/9-A (KLM-5/7-A)	4
II. Part list (part sets)	5
III. General assembly description	8
IV. Anchors – placing in concrete	9
V. Pillars installation	10
VI. Net hoisting	17
VII. Final adjusting	20
VIII. Maintenance and periodical inspection	21
IX. Technical drawings	22
Drawing no. 1 – Rear cage pillar	22
Drawing no. 2 – Cage gate and extreme pillar	23
Drawing no. 3 – General cage projection	24
Drawing no. 4a – Foundation block for rear cage pillars	25
Drawing no. 4b – Foundation block for cage extreme pillars	26
Drawing no. 5 – Projection of the cage	27
Drawing no. 6 – Plan of the foundation blocks for cage pillars	28
Drawing no. 7 – Pillars installation	29
X. How to play the attached instructional video	30
XI. Declaration	31







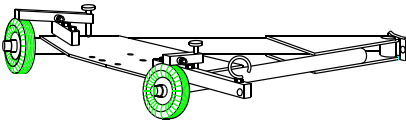
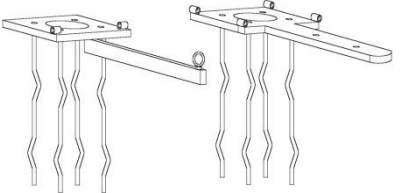
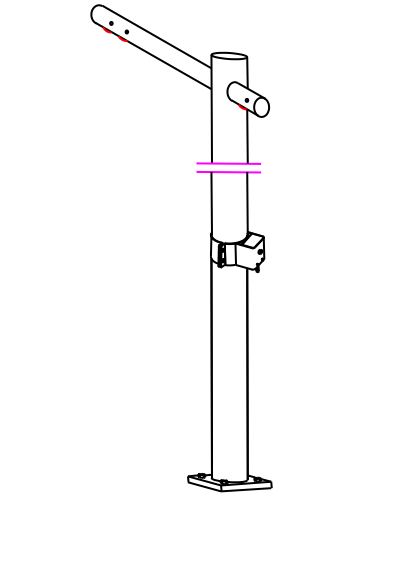
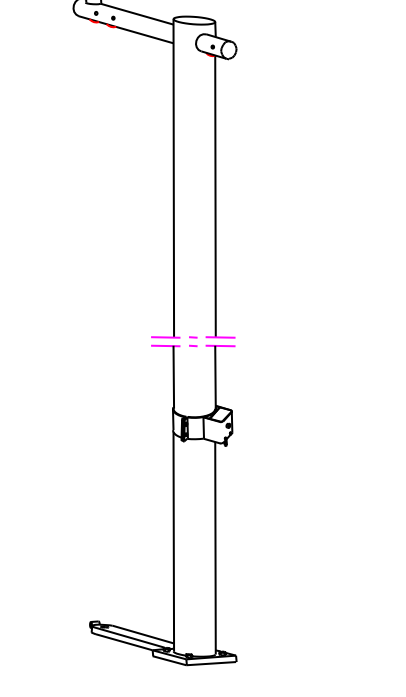

## I. Characteristics of the hammer/discus safety cage KLM-7/9-A (KLM-5/7-A)

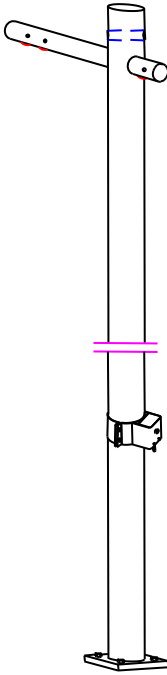
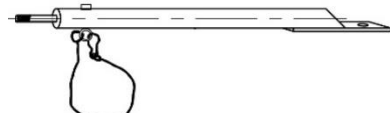

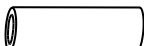
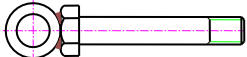



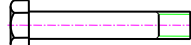

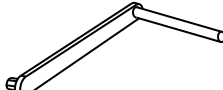
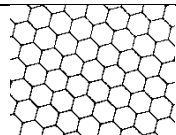

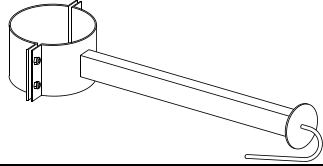
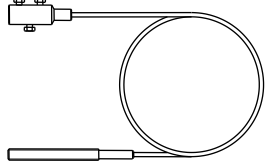
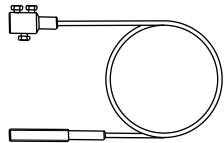
The safety cage for hammer and discus throwing is a modern construction made of high quality materials. Main characteristic features of the cage are as follows:

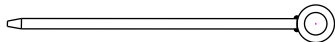
1. Innovative construction:
  - Net is hung in such a way that it does not touch the aluminium structure in any point. That is attained by means of the one-pillar mobile door construction. It is a unique solution, which cannot be spotted in other constructions – protected by patent.
  - Cage pillars are not linked with each other by means of inflexible elements, that is why they work independently.
  - Application of anchors (instead of popular sockets) eliminates rusting caused by water penetration in the lower parts of the cage.
2. High durability:
  - Cage construction is made of aluminium which is anodized in silver colour.
  - All tube ends are protected with plastic caps. They stop water from getting inside the construction and provide good finish and appearance.
  - Steel elements are hot galvanized or electro-galvanized. All ratchet mechanism casings are additionally coated with powder paint.
3. High quality:
  - Cage conforms to the international quality standards: Rule 192 (point 1,2,5 and 6) of the Competition Rules of the International Association of Athletics Federations (IAAF).
  - Cage is equipped with high quality, certified net. Net is strained and fastened at the cage bottom by means of steel cable and hooks. That lets us eliminate traditional bags filled with sand.
4. Easy operating:
  - Cage can be assembled and disassembled without using a crane or an extension arm. Assembly (or disassembly) using POLANIK cage gate lift CGL16-3 takes approximately 4÷5 hours done by 3÷4 people. When the lift CGL16-3 is not used 4÷6 people are required to install the cage gate.
  - Pillars are fastened to anchors embedded in concrete. That system of pillar installation enables you to dismount the cage and cover the anchor foundations with synthetic surface in order to use the ground for other purposes.
  - Each pillar is equipped with the self-blocking mechanism of lifting and lowering the net by means of crank.
  - Each gate door moves on two widely spread rubber wheels what makes the gate very stable.

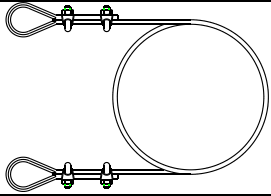
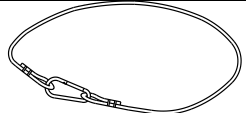
## II. Part list (part sets)

Item	Part/set description	Q-ty Pcs.	Material	Draw. no.	Part/set sketch
1	Gate car	2	Hot galvanized steel	2,38	
2	<b>K6-0027 anchor set available separately</b> (6 pcs + extreme pillar anchor with flat bar – 2 pcs + screw M 20x50 (36 pcs) + washer 20 (36 pcs))	6+2	Electro-galvanized steel	1, 2, 3, 4a, 4b, 6, 7	
3	Rear pillar (length approx. KLM-7/9-A ~ 7 m and KLM-5/7-A ~5 m)	6	Anodized aluminium and electro-galvanized steel	1, 3	
4	Extreme pillar (length approx. KLM-7/9-A ~ 9 m and KLM-5/7-A ~ 7 m)	2	Anodized aluminium and electro-galvanized steel	2, 3, 4b	

Item	Part/set description	Q-ty Pcs.	Material	Draw. no.	Part/set sketch
5	Gate pillar (length approx. KLM-7/9-A ~ 9 m and KLM-5/7- A ~ 7 m) + screw M 20x60 (8 pcs) + nut M 20 (8 pcs) + washer 20 (8 pcs)	2	Anodized aluminium and electro- galvanized steel	2, 3	
6	Upper gate arm, with safety wire	2	Hot galvanized steel	2, 3	
7	Hinge axle $\varnothing 11 \times 350$	1	Electro- galvanized steel	7B/7C/ 7D	
8	Car sleeve $\varnothing 20 / \varnothing 30$	2	Electro- galvanized steel	2	
9	Car axle screw M 20x120	2	Electro- galvanized steel	2	
10	Washer $\varnothing 20 / \varnothing 40 \times 3$	2	Electro- galvanized steel	2	
11	Upper arm sleeve	2	Electro- galvanized steel	2	
12	Press bolt M 16x40	2	Electro- galvanized steel	2	
13	Clamping screw for upper arm M 20x160	2	Electro- galvanized steel	2	
14	Blocking tab washer 20	2	-	2	
15	Crank	2	Electro- galvanized steel	1, 2, 3	
16	Net with rim white rope	1	Synthetic fibre	3	

Item	Part/set description	Q-ty Pcs.	Material	Draw. no.	Part/set sketch
17	Side cable arm + screw M 8x25 (16 pcs) + nut M 8 (16 pcs) + washer 8 (16 pcs)	4	Electro- galvanized steel and powder painted	2	
18	Bottom net tension cable length approx. ~21,7 m + nut M 16 (1 pc) + washer 16 (1 pc)	1	Electro- galvanized steel	-	
19	Gate car net tension cable length approx. 2 m + nut M 16 (1 pc) + washer 16 (1 pc)	2	Electro- galvanized steel	-	
20	Net hooks	80	Electro- galvanized steel	-	
21	Blocking pin	2	Electro- galvanized steel	2	
22	Blocking sleeve	4	Electro- galvanized steel	2	
23	Edge steel cable of the gate panel length ~8,8 m (threaded through the net meshes)	2	Electro- galvanized steel	-	
24	Horizontal stay ropes length ~1,6 m	8	Synthetic fibre	-	
25	Nord-Lock blocking washer 16	2	-	3	
26	Wrench 30/24 for upper gate arm item 6	1	Electro- galvanized steel	-	
27	Split pin	2			
28	Split pin for upper arm	2	Stainless steel	3	
29	Crown nut	2	Stainless steel	3	

### III. General assembly description

The sequence of the assembly operations is described in detail in the next chapters of this manual. The instruction film on the enclosed CD-ROM also presents the assembly process. We ship the cage to a customer in partially assembled units. The extension arm with rollers and the ratchet mechanism are already installed in each cage pillar (see drawing no. 1 and 2). The cage construction consists of 10 pillars: 6 rear pillars (item 3), 2 extreme pillars (item 4) and 2 gate pillars (item 5). Extreme pillars (item 4) have got special flat steel welded to their feet. Gate pillars (item 5) have got mounting holes at their top ends for installing upper gate arms (item 6). Gate pillars are fastened to gate cars (item 1) and they constitute the cage gate. Rear and extreme pillars are fastened to anchors (item 2), which are embedded in concrete according to the plan of the foundation blocks – drawing no. 6. The anchors for rear pillars should be positioned in concrete in such a way that their hinges face the throwing circle. The anchors for extreme pillars are fixed in opposite direction to the throwing circle. Installed pillars constitute the main structure of the cage which is ready for affixing the net and hoisting it.



#### IV. Anchors – placing in concrete

The anchors for rear pillars should be positioned in concrete so that **their hinges face the throwing circle**. The anchors for extreme pillars ought to be positioned in concrete so that **their flat bars face the inside of the cage**.

**Attention!** All anchors (item 2, drawing no. 4a, 4b, 1, 2 and 3) must be embedded in the foundation blocks in such a way that their upper surfaces are exactly horizontal, then pillars will be precisely in vertical position. **Each anchor must be fixed according to the direction marks, see drawing no. 6**. During the embedding process please make sure that the screws situated in the upper plates of the anchors are fully screwed down and their threads are well protected by rubber sleeves. If concrete plasters the threads of the screws it will be impossible to install the pillars. Foundation blocks are shown in drawing no. 4a and 4b.

There are special direction marks painted on each anchor (drawing a and b). Drawing b is showing the anchors for extreme pillars (item 4, drawing no. 2 and 3). Drawing a is presenting the anchors of rear pillars. All direction marks on the anchors must correspond with the direction lines in drawing no. 6. The positions of the anchor hinges should be also checked and compared with drawing no. 6. All supplied anchors are ready for embedding (screws are fully screwed down and their threads coated with rubber sleeves).

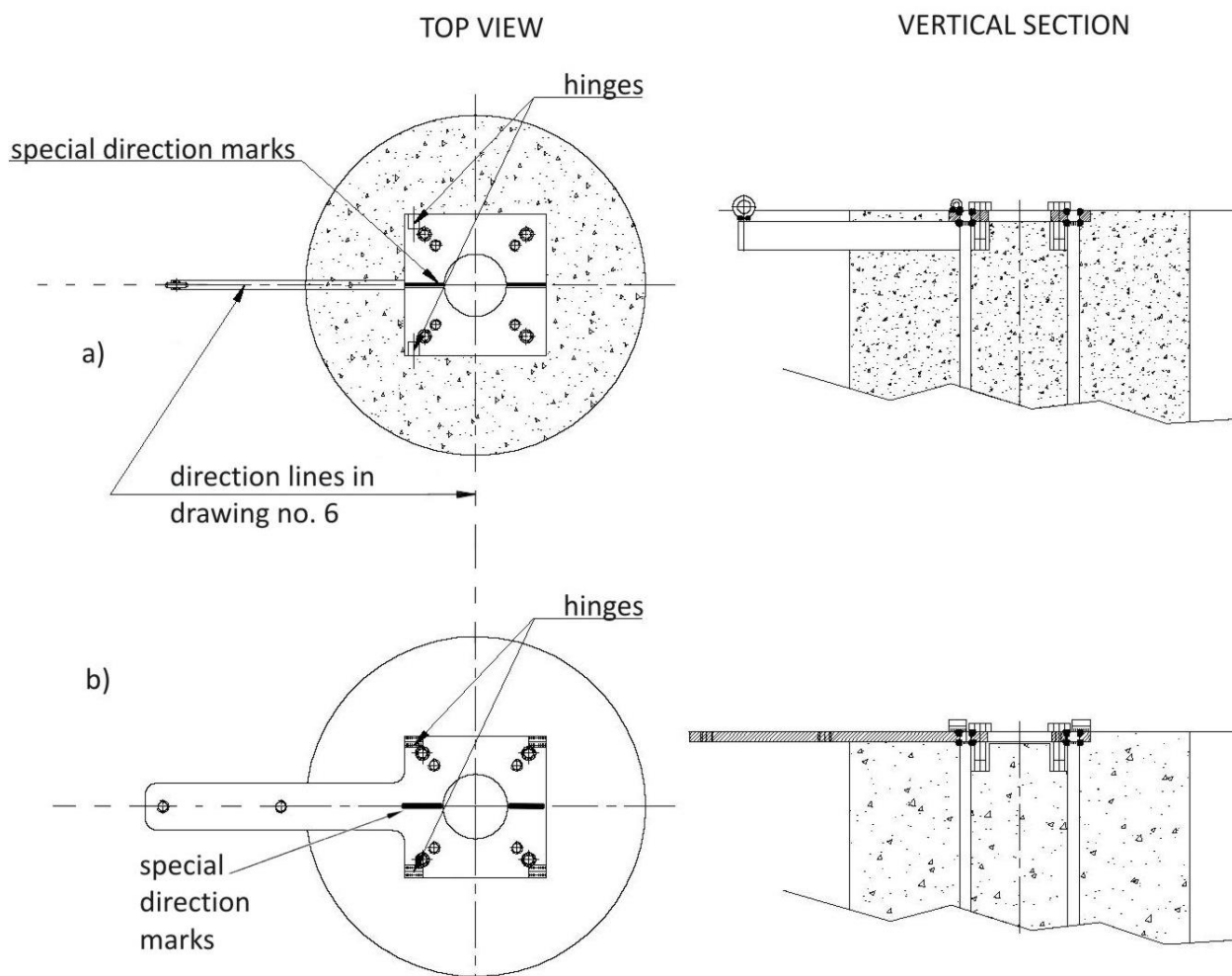

**Attention!** The anchors should be placed in the concrete of the class B20 quality or higher. Each time the anchor is put into the foundation the concrete should be mixed, so that it covers tightly the ribbed bars and there are no air chambers inside. During the concrete setting the foundations should be moistened (in the first week twice a day, in the second week once a day). You ought to wait minimum 2 weeks before you proceed with the installation of the pillars.

## V. Pillars installation



**WARNING: failure to follow the sequence of these assembly operations could result in serious accident or damages to the cage construction.**

The installation of rear and central pillars (item 3) on anchors (item 2) is done in the following way: we unpack delivered pillars, then we remove blocking screws (M 8x16) from the ratchet mechanisms and loosen steel lines, next the lines should be unwound a little and their ends ought to be temporarily fastened to pillars at the level of ratchet mechanisms (drawing no. 1 and 2), after that rear pillars should be installed one by one according to the sequence shown below:

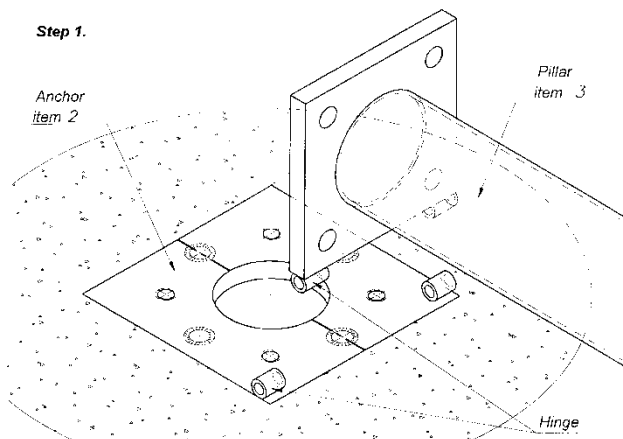

**Step 1.**  
Position the pillar in the anchor hinges.

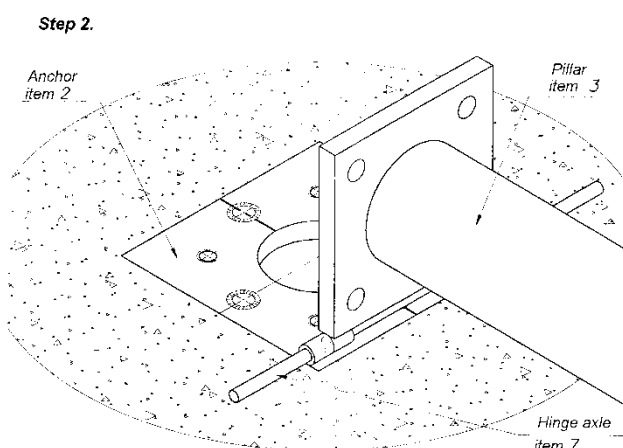

**Step 2.**  
Slide hinge axle (item 7) into the anchor hinges.

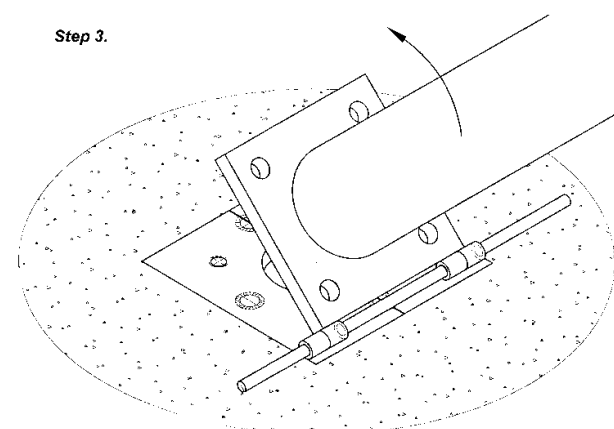

**Step 3.**  
Lift the pillar to vertical position.

**Step 4.**

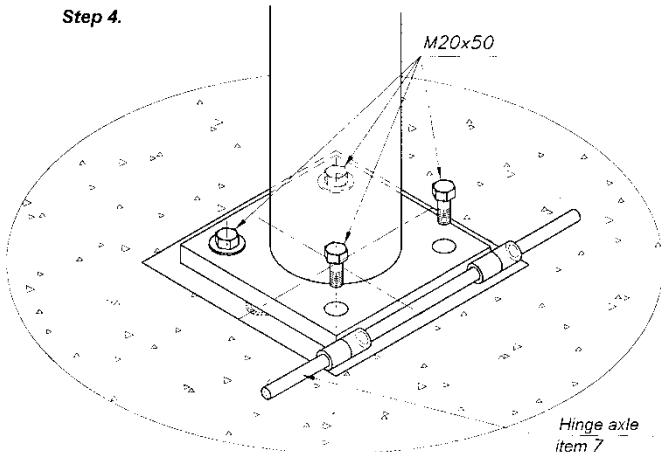

**Step 4.**

While one man is supporting the pillar in upright position, the other person is screwing it to the anchor in the following sequence:

- screw down two screws (M 20 x 50) opposite the anchor hinges,
- then screw down two remaining screws (M 20 x 50) next to the anchor hinges,
- remove hinge axle (item 7).

After the assembly of the rear pillars we can start installing extreme pillars (item 4) and gate pillars (item 5). **All assembly operations of gate, gate cars and extreme pillars are executed before the whole gate construction is lifted to vertical position.** Extreme pillars should be raised together with gate doors in that way there is no need to use a crane or an extension arm, because we are not supposed to work at the height of 9 m (or 7 m). The assembly process is done as follows:

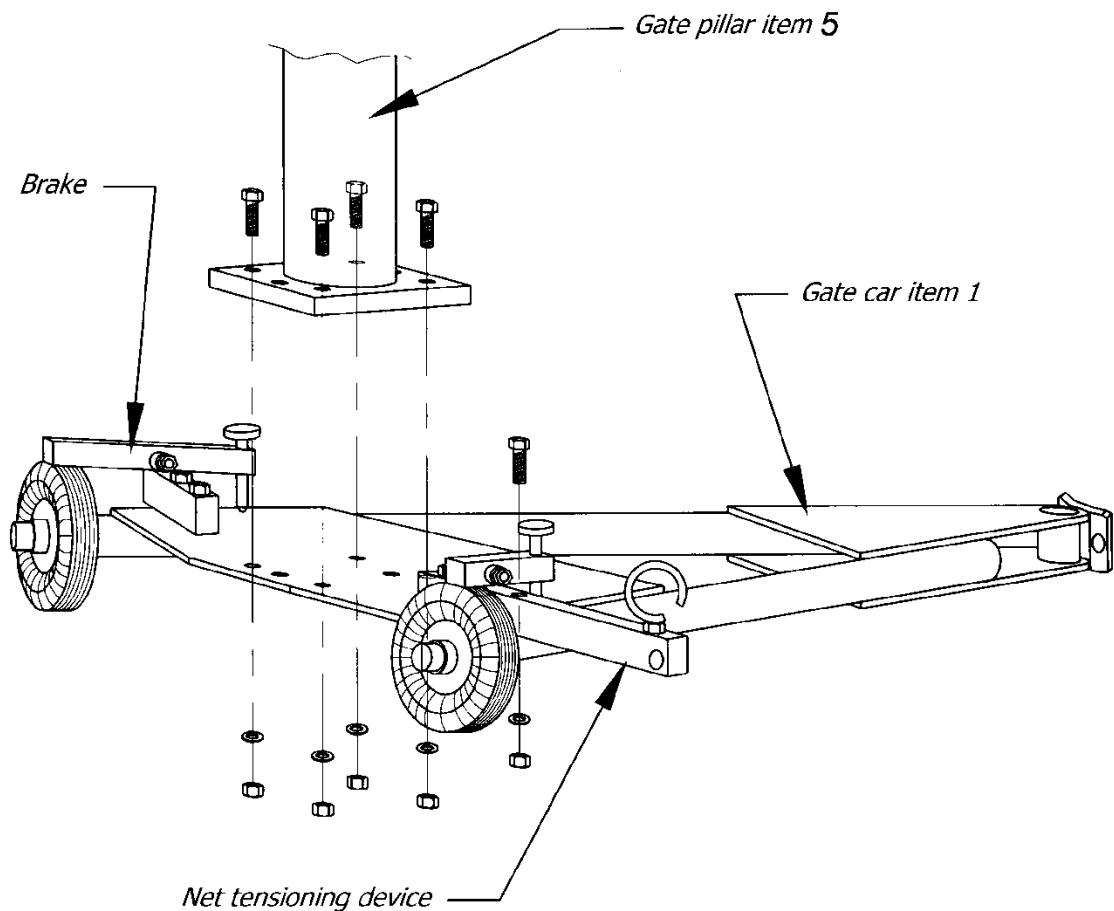



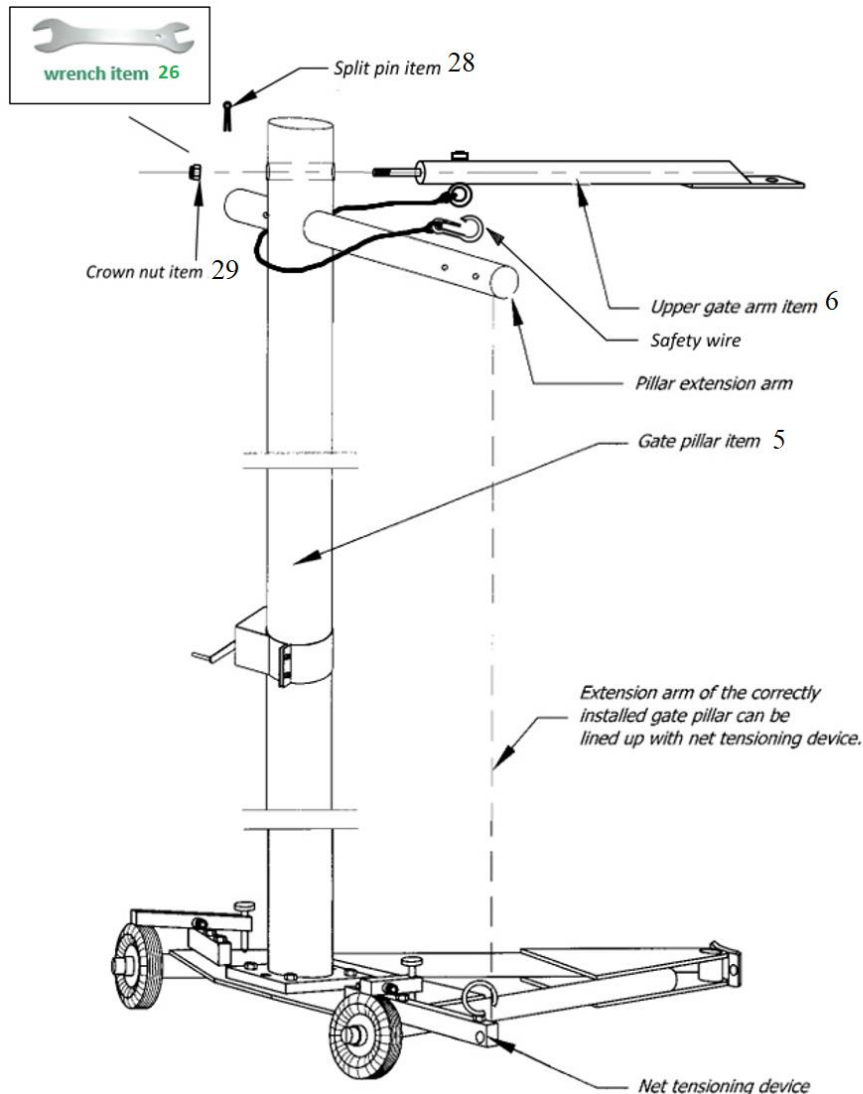

A. Unscrew net tensioning device situated in gate car (item 1) and install it in its working position as shown in the above picture.

Screw gate pillar (item 5) to gate car (item 1) by means of four screws (M 20 x 60). Gate pillar should be placed on gate car in such a way that the extension arm of gate pillar and the net tensioning device are lined up.

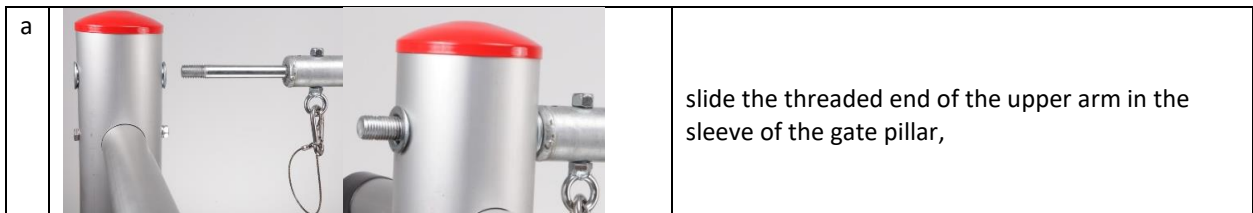

B. Install upper gate arm (item 6) at the top of gate pillar – according to the rotation axis of gate car (item 1). Use split pin (item 28) and crown nut (item 29). Use the included metric wrench (item 26) to install the arm. **Attention! The crown nut (item 29) should be scrupulously screwed down (until you feel resistance), and it must be secured with the split pin (item 28). The link between the upper gate arm (item 6) and the gate pillar (item 5) plays a significant part in the safety of the cage construction, and it is done in the following way:**



b		install the crown nut (item 15) , tighten it with the wrench (item 27) until you feel the resistance,
c		slide in the split pin in the threaded rod of the arm (item 14),
d		bend the split pin ends to block it in the rod,
e		use the safety wire to fasten the pillar to the arm.

C. Connect extreme pillar (item 4) with the assembled gate, it is a rotational joint. Car gate is connected with the foot of extreme pillar by means of car axle screw M 20 x 120 (item 9), car sleeve  $\varnothing 20 / \varnothing 30$  (item 8) and washer  $\varnothing 20 / \varnothing 40 \times 3$  (item 10). Upper gate arm is linked with the extension arm of extreme pillar by means of press bolt M 16 x 40 (item 12), Nord-Lock blocking washer (item 25) and upper arm sleeve (item 11). Sleeves (item 11 and 8) have to be greased before installing. Use included wrench (item 26) to install the press bolt (item 12).

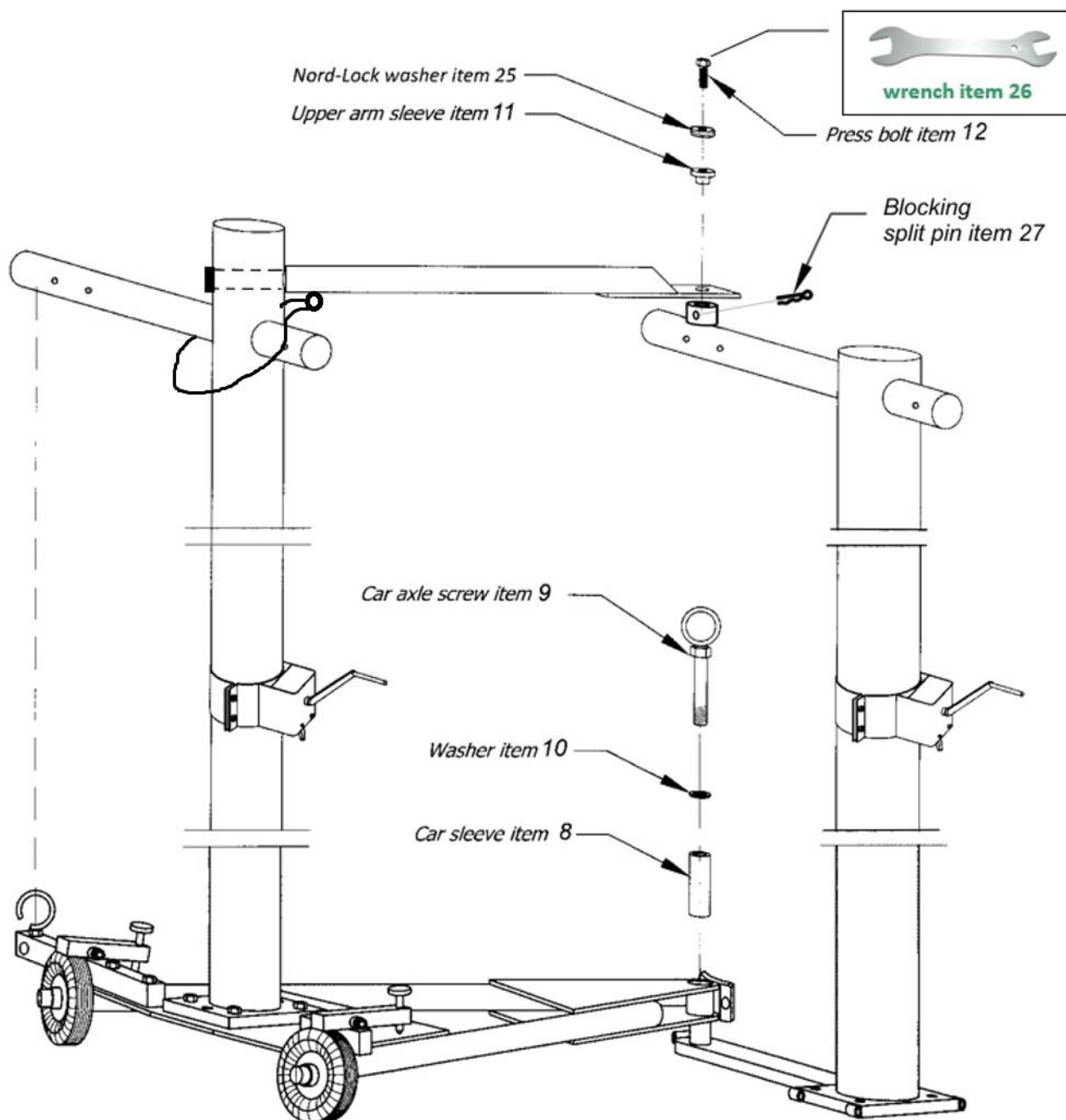

**Attention! The press bolt (item 12) should be scrupulously screwed down (until you feel resistance). The link between the upper gate arm (item 6) and the gate pillar (item 5) plays a significant part in the safety of the cage construction. When the press bolt (item 12) is screwed down, it must be secured with split pin (item 27).**

**The correct connection is shown below.**

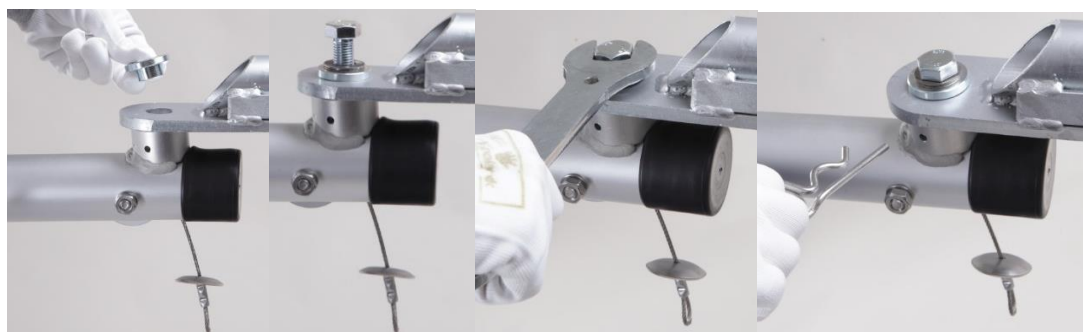

- D. The assembled gate door is placed next to the anchor for extreme pillar. Then we put the foot of extreme pillar into the anchor hinges and slide in hinge axle (item 7) according to stage 1 and 2 of pillars installation (see Chapter V). Next we swivel gate car together with gate pillar around the rotation axis of the gate door to the angle of 90°. During that operation extreme pillar is resting on the ground. The wheels of gate car and whole gate pillar are being hold at the height of 2 m approx.
- E. Now side cable arms (item 17) are to be installed, two for each gate pillar. The arms (item 17) are mounted at approx. 3 m and 6 m ( 2,5 m and 5,5 m for KLM-5/7-A) measured from gate car (item 1) – see the drawing below. The mounting points of the arms are labelled with blue belts on gate pillars. **At this stage you can also install cage pillar shields (OS290, OS296) and soft pads (OM-150), which are available as optional accessories. Please see the instruction manual of the shields for further information.**
- F. That is the starting point of the last stage which is lifting the whole gate door to vertical position. The gate car and the gate pillar are positioned 2 m from the ground (a pallet put vertically can be used to support the gate door). We recommend using a Polanik cage gate lift CGL16-3 at that stage (see below the image). CGL16-3 is available as optional accessories. Please see the gate lift instruction manual for further information on lifting procedures. To lift the gate door without the cage gate lift 4-6 men are required. When the gate door has been raised we can screw extreme pillar to its anchor according to step 3 and 4 of pillars installation (see Chapter V).



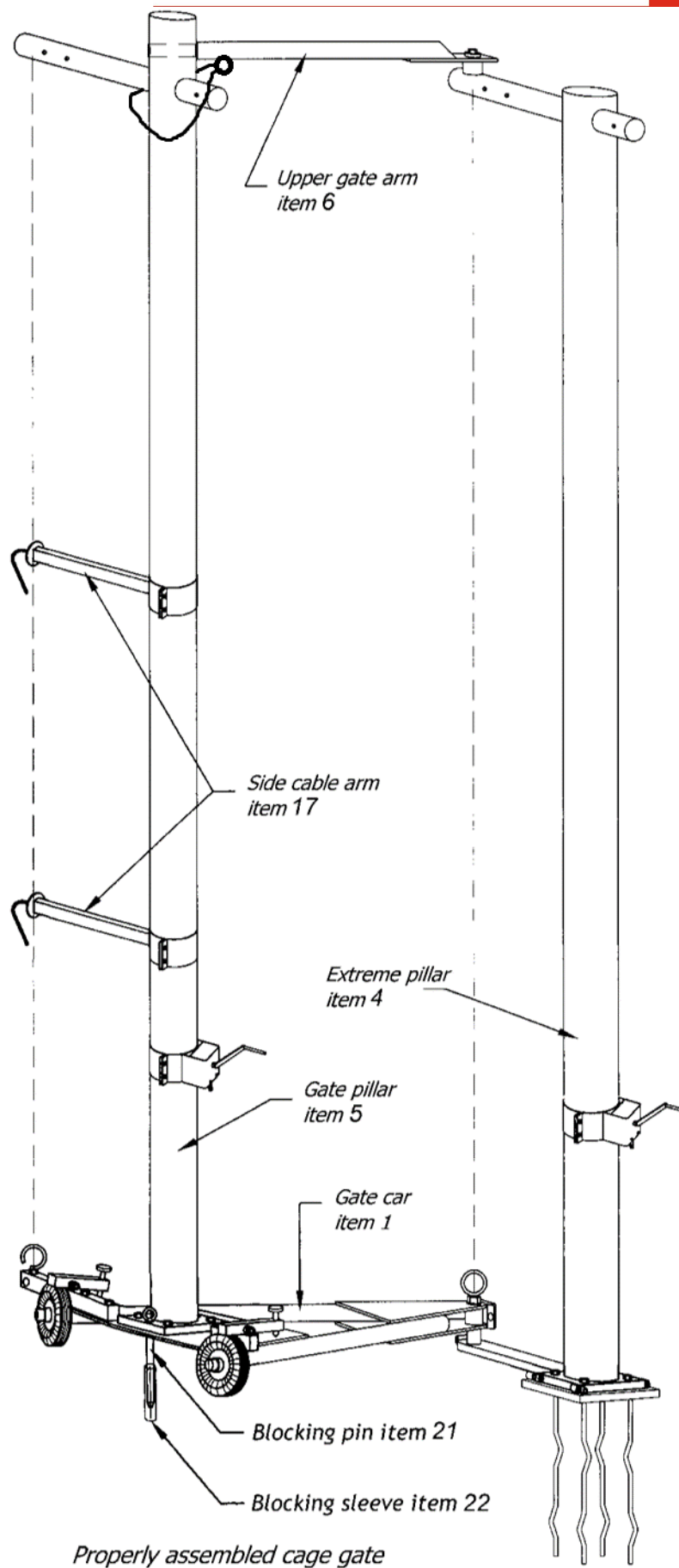



## VI. Net hoisting

The installed pillars and gate doors constitute the main cage construction which is ready for installing and hoisting the net. Firstly bottom net tension cable (item 18) ought to be threaded through the eyelets which are located in the net straining arms of anchors (item 2), see the drawing on the next page. Cable regulating screw will help us to strain it. Next we do the same with two gate car cables (item 19).

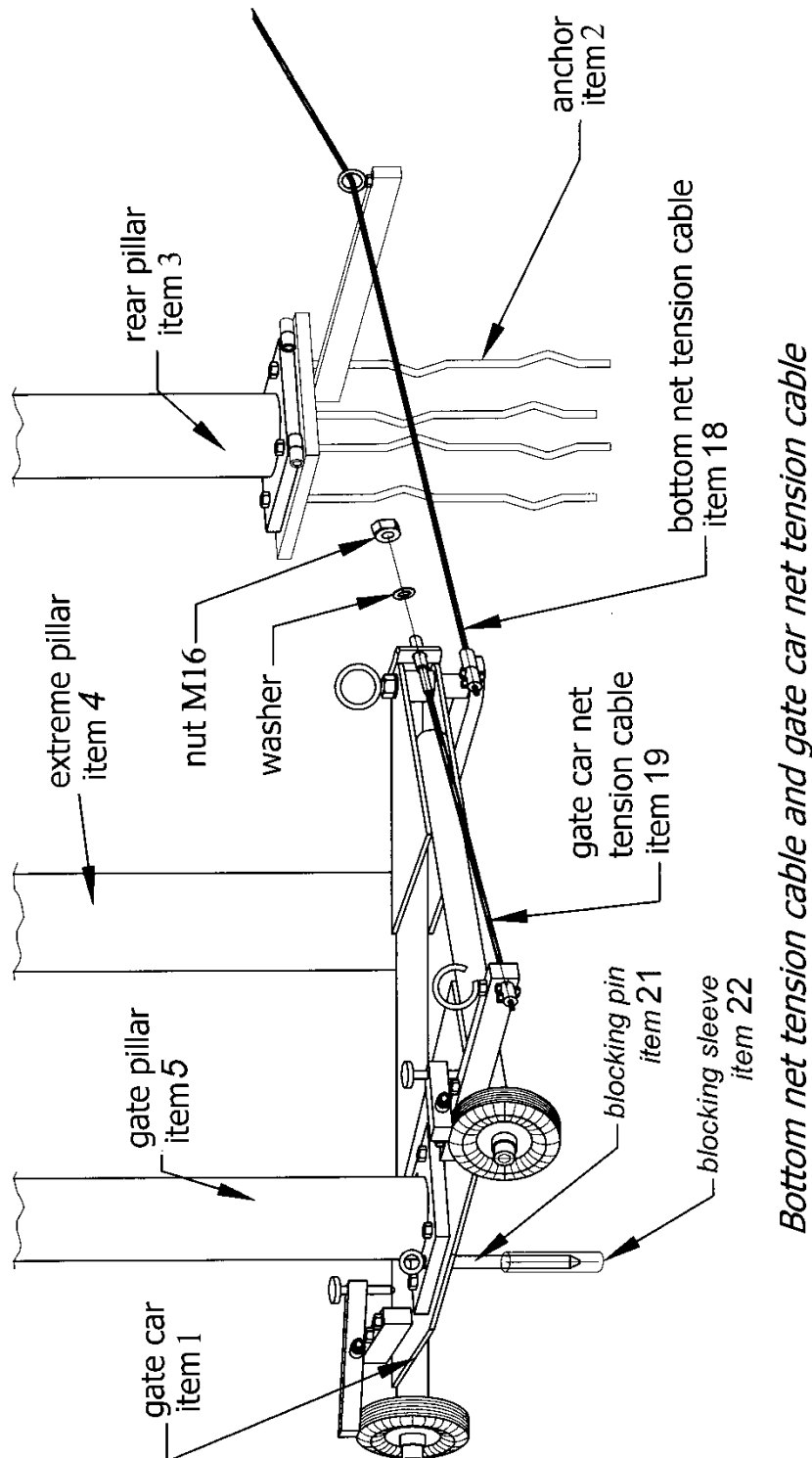

*Bottom net tension cable and gate car net tension cable*

When we complete these preliminary works, the net can be laid down on its circumference according to drawing no. 5. Then we begin with attaching it to the steel ropes of the pillars by means of special catches. One end of each steel rope is fixed permanently to the bobbin of the ratchet mechanism and the other one, which has been temporarily fastened to pillar (see Chapter V), should be now untied and attached to the net. That operation is repeated at each pillar.

Next edge steel cable of the gate panel (item 23) should be installed:

a) edge steel cables (item 23) are threaded through the net meshes near the side edges of the net,



b) one end of the steel cable (item 23) is to be linked to the snap hook of the gate pillar wire rope,



c) the bottom end of the edge steel cable (item 23) is fastened to the gate car.



Now we can hoist the net. The lifting of the net should be executed successively by approx. 2 m at each pillar and ought to be continued up to the maximum height apart from the gate pillars, at which the net must be lower than the maximum height by approx. 20 cm. **Do not lift the steel ropes of the pillars without the net – it may not be possible to lower them without the appropriate load.**

Next the net is to be hooked onto the side arms (item 17):

a) auxiliary ropes which are attached to the net edge will help you to hook the net without a ladder,



b) two people manoeuvre the net edge into the side arm hook easily,



c) properly hooked net.



If the net is fastened at the both sides of the gate, you can raise the net at the gate pillars to the maximum height using the crank (item 15). The lower edge of the net should be folded under tension cable (item 18) and gate car cables (item 19), next we strain the net and fix the edge to the meshes with supplied hooks (item 20). **That way the net surface will not touch the aluminium elements of the cage construction in any point - it is extremely important for correct impact absorption and pillars' life.**



In order to provide proper net position (during strong winds the net may deflect from the required projection like a sail) horizontal stay ropes 1,6 m long (item 24) are supplied. The net is tied to each pillar (except for the gate pillars) at 2m from the ground. **Please make sure that the rope loops around the pillars are loose enough to provide easy sliding. That allows you to lower the net smoothly to its idle position – max. 1/3 of its height, which is recommended for breaks in competitions or training periods, especially during strong winds.**

## VII. Final adjusting

- When the cage construction is mounted and the net is raised, the blocking sleeves (item 22) should be installed in the concrete paths. Please position the holes for the sleeves according to the drawing below. The sleeves enable you to secure the gate doors with the blocking pins (item no. 21) at two points: 112 cm from the cage axis and 360 cm from the cage axis), and consequently to narrow the danger sector if there are right-handed and left-handed throwers in the competition.

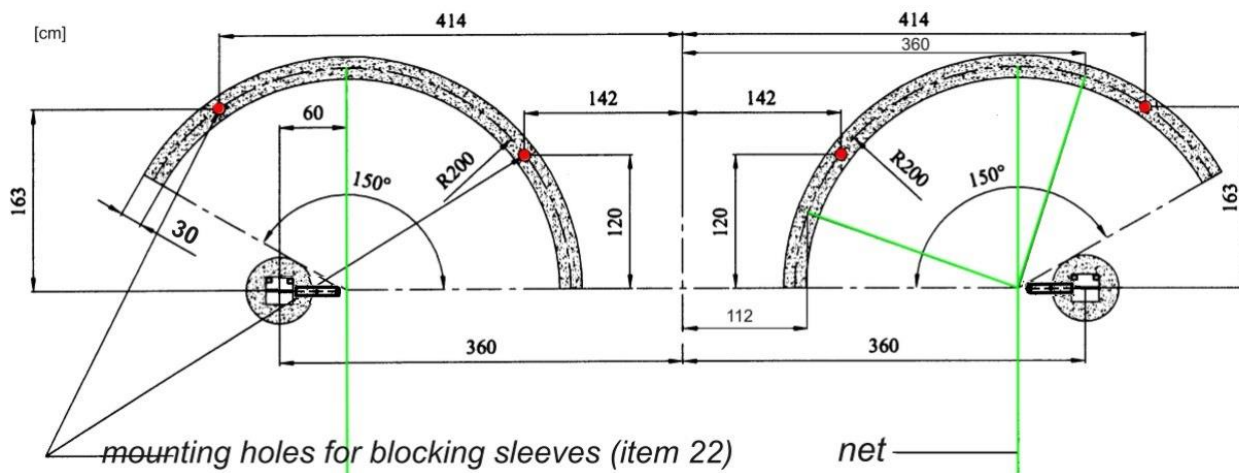

- The ratchet mechanisms of the pillars should be blocked with screws (M 8 x 20) or padlocks. That secures the net against accidental loosening.
- Each gate car is equipped with two brakes. After positioning the gate doors the brakes ought to be tightened up.
- The cage is ready for use provided that the above operations are completed.

### VIII. Maintenance and periodical inspection

As the producer we have done our best to make the cage guarantee maximum safety level, be easily operated and reliable in use. However the cage like any other pieces of sports equipment requires periodical inspections and must be used according to the instruction manual, the IAAF rules and operated by authorized personnel.

To keep the cage in good condition, the following maintenance operations and periodical inspections should be executed after every athletics season:

- Check the tensile strength of the net (use the samples) according to the IAAF instructions.
- Clean and grease the steel lines of the cage pillars.
- Grease the press bolt of the gate car brakes.
- Grease the sleeves of the gate cars.
- Remove the cranks. Keep them in safe place for future use.
- Fold the net provided it is dry and tie it. Keep it in safe place.
- **The steel lines should be always secured and strained when the net is taken off. It prevents the steel lines from hitting the anodized aluminium surfaces of the pillars.**
- **Do not lift the steel lines of the pillars without the net – it may not be possible to lower them if they are not loaded.**
- **During idle periods the net must be absolutely lowered. Lift the net only for using.**
- **In case of strong winds, during which competition throwing events (see the IAAF rules) and training meetings cannot be conducted, the net must be absolutely lowered.**
- **During idle periods, when the net is not dismantled for storage, the gate doors must be closed, blocked with blocking pins (item 21), the gate car brakes must be tightened. Additionally the gate doors should be secured with rope.**

Even the best technical solutions cannot substitute for common sense. Hammer and discus throwing should be taken place under the supervision of qualified trainers. The producer shall not be liable for any incidents caused by improper cage assembly or its misuse.

## IX. Technical drawings

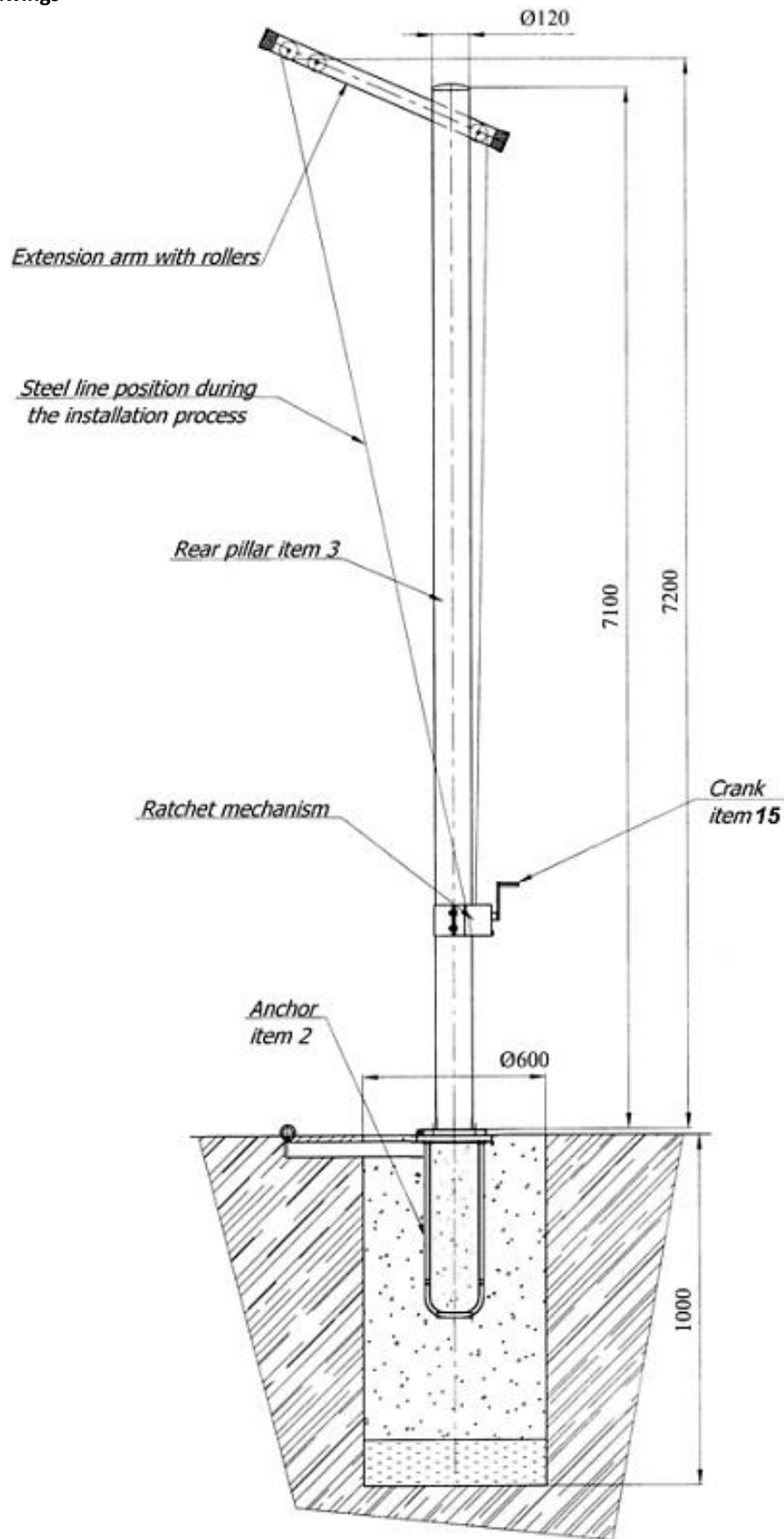

*Rear pillar*  
**Drawing no.1**

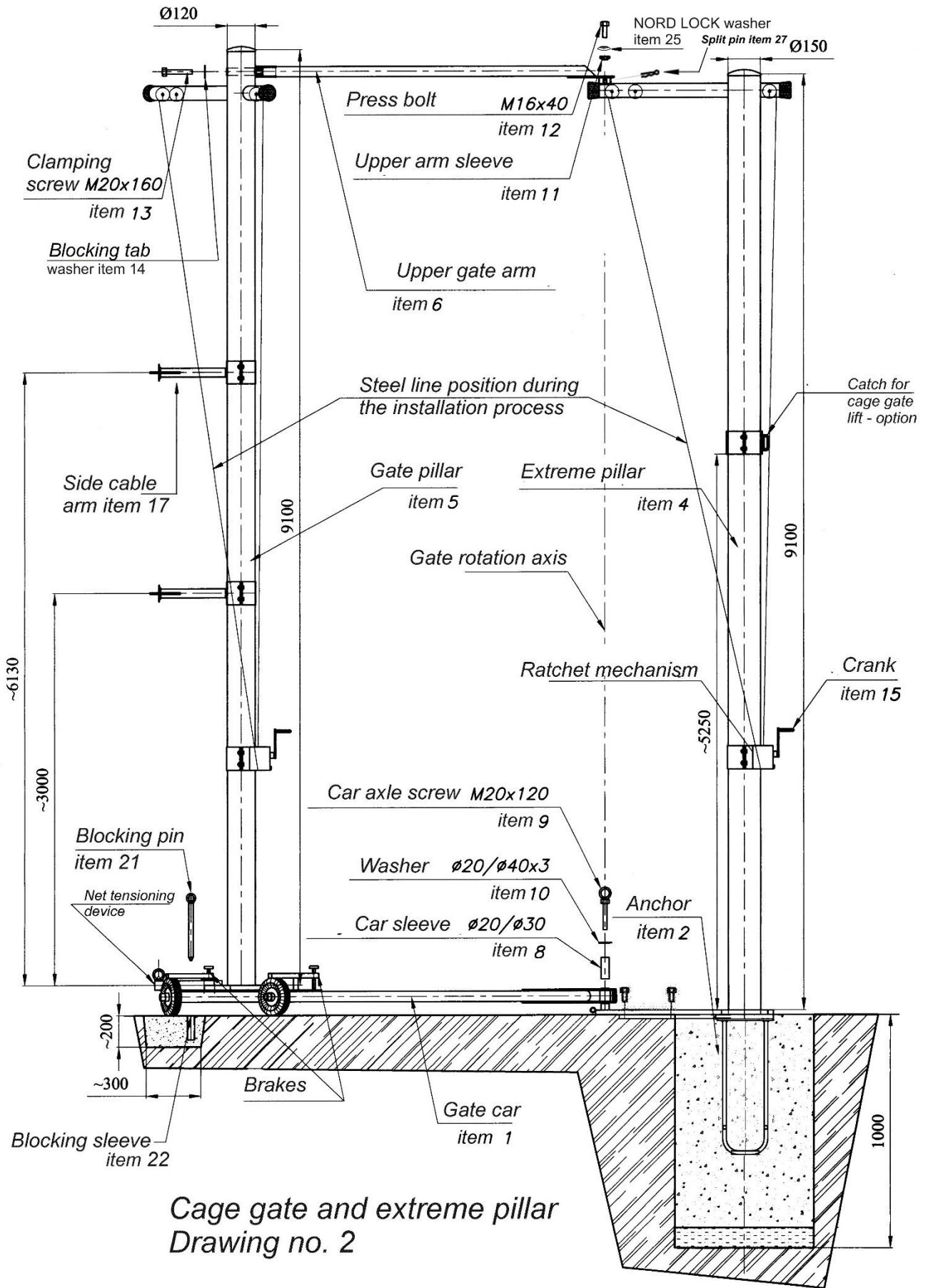

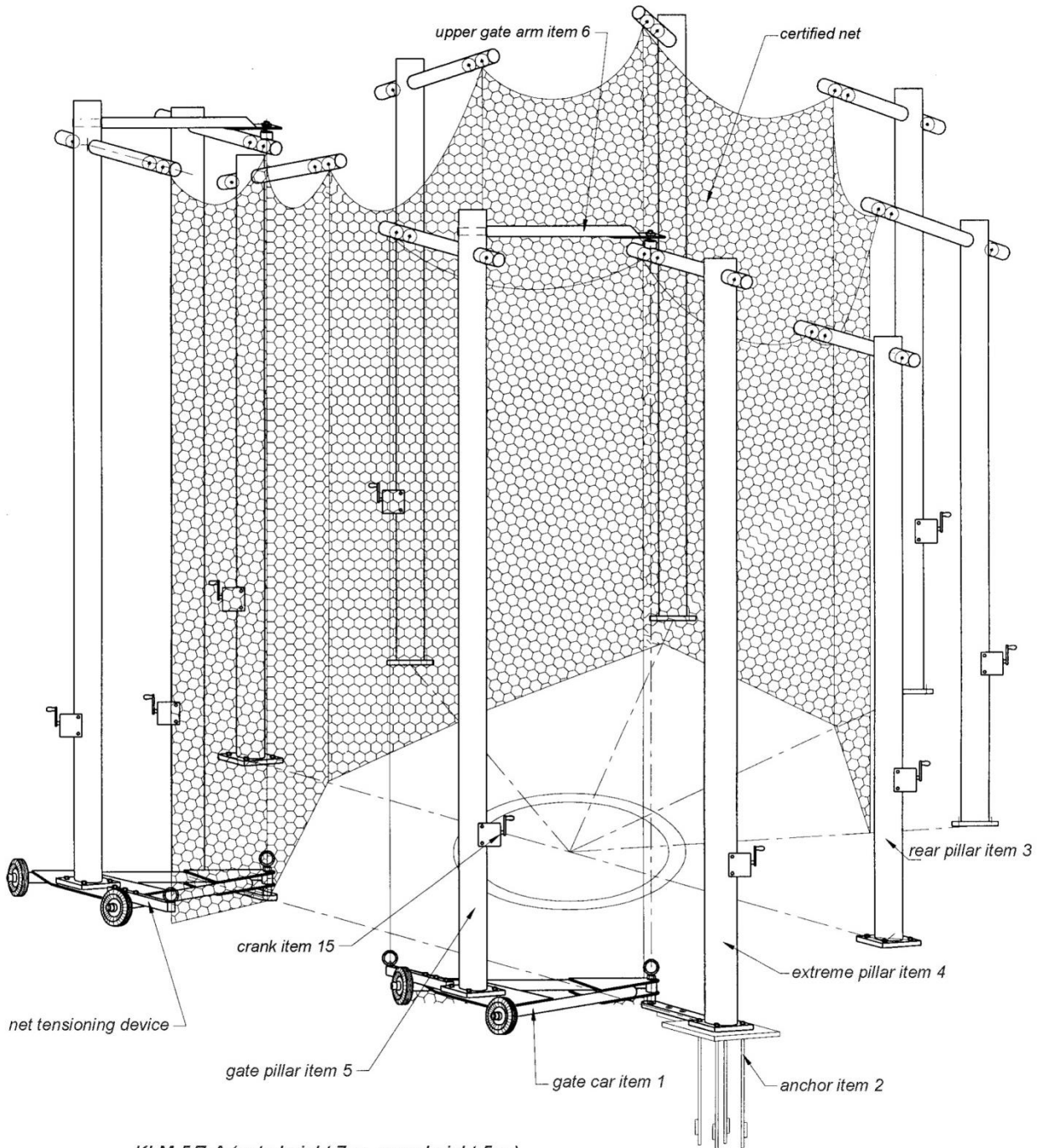

KLM-5/7-A (gate height 7 m, cage height 5 m)  
KLM-7/9-A (gate height 9 m, cage height 7 m)

**General cage projection  
Drawing no. 3**



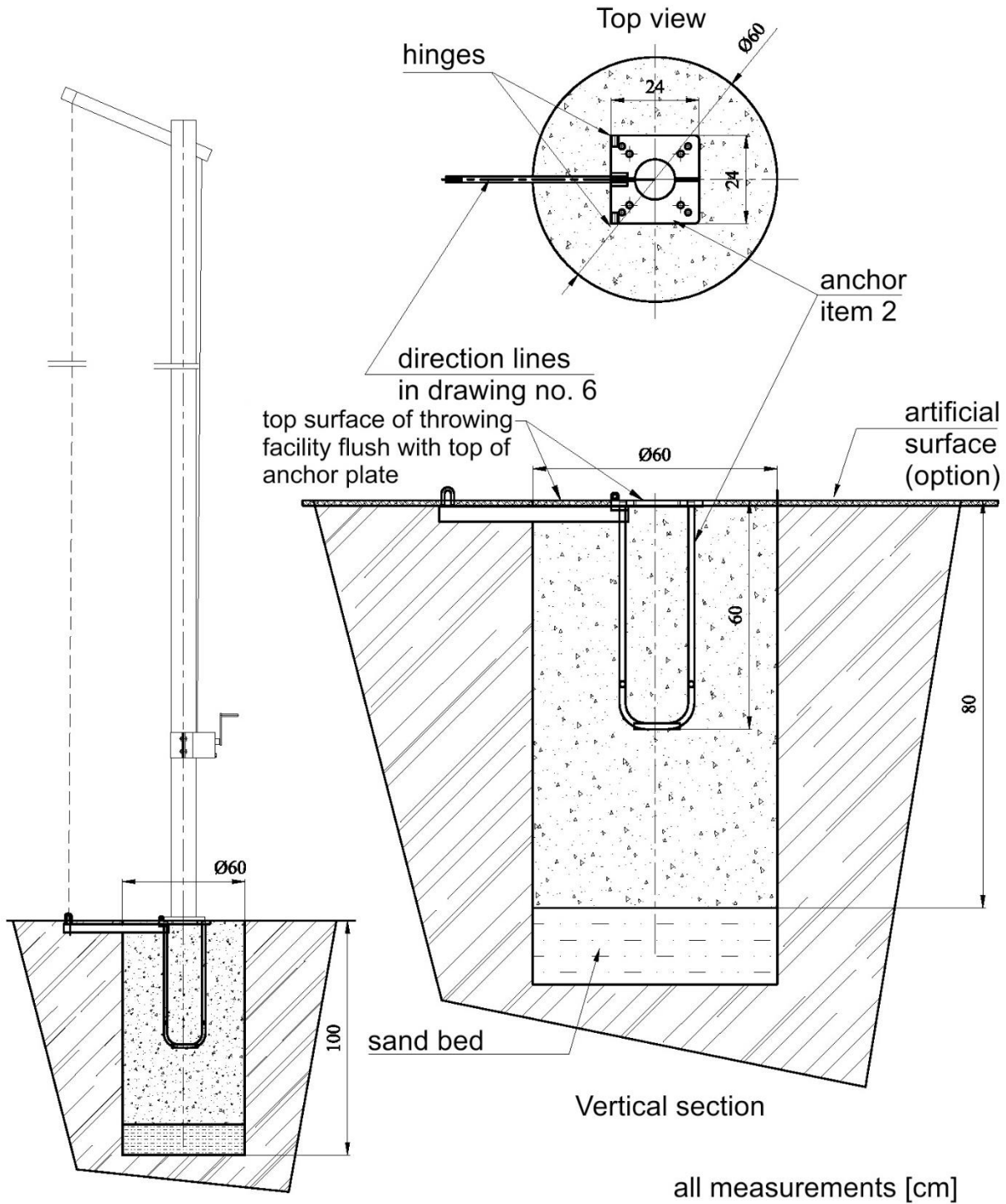

Foundation block of cage pillar (6 pcs)

Drawing no. 4a

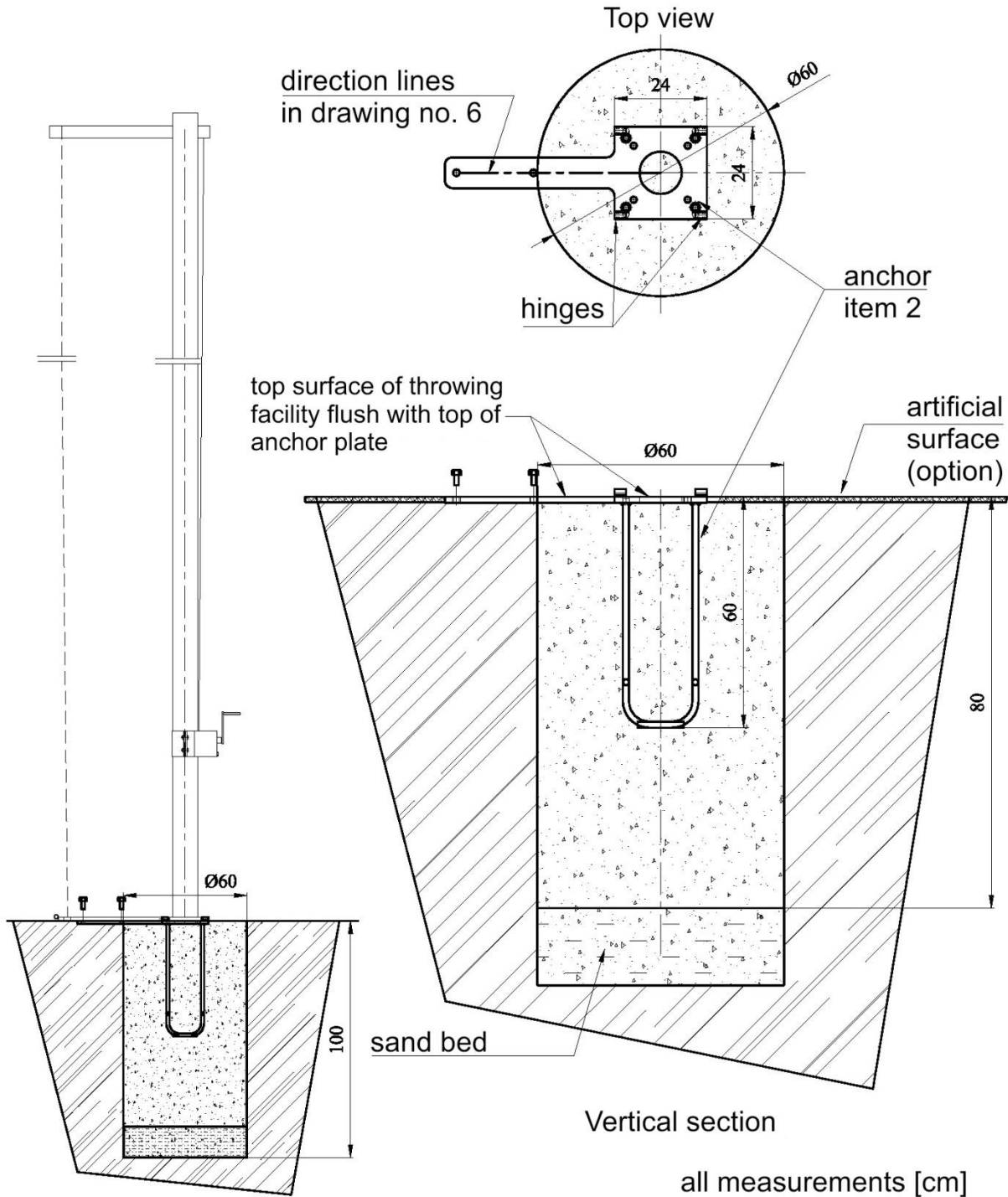

Foundation block of cage extreme pillar (2 pcs)

Drawing no. 4b

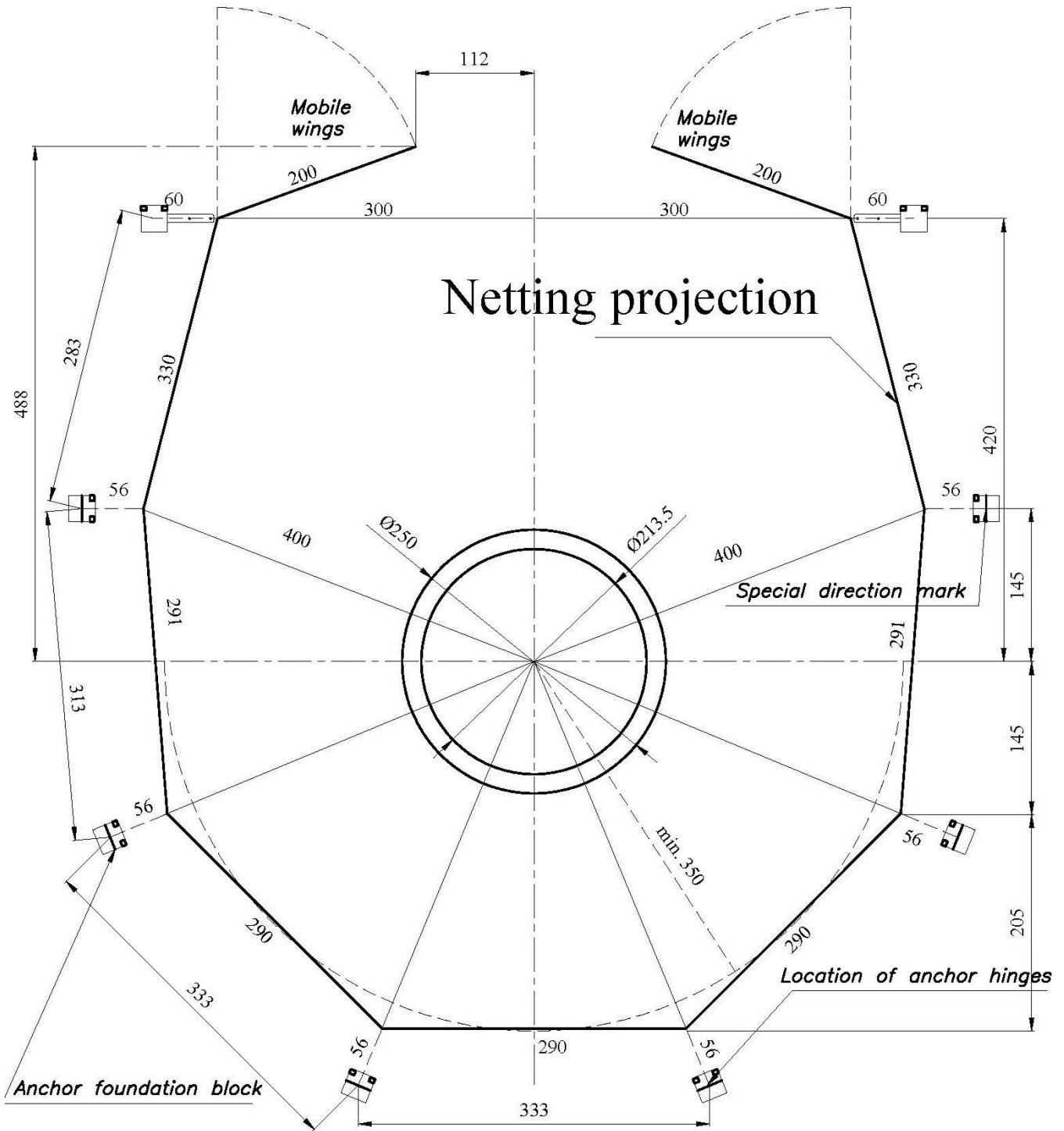

All dimensions in [ cm ]

## Projection of the cage Drawing no. 5

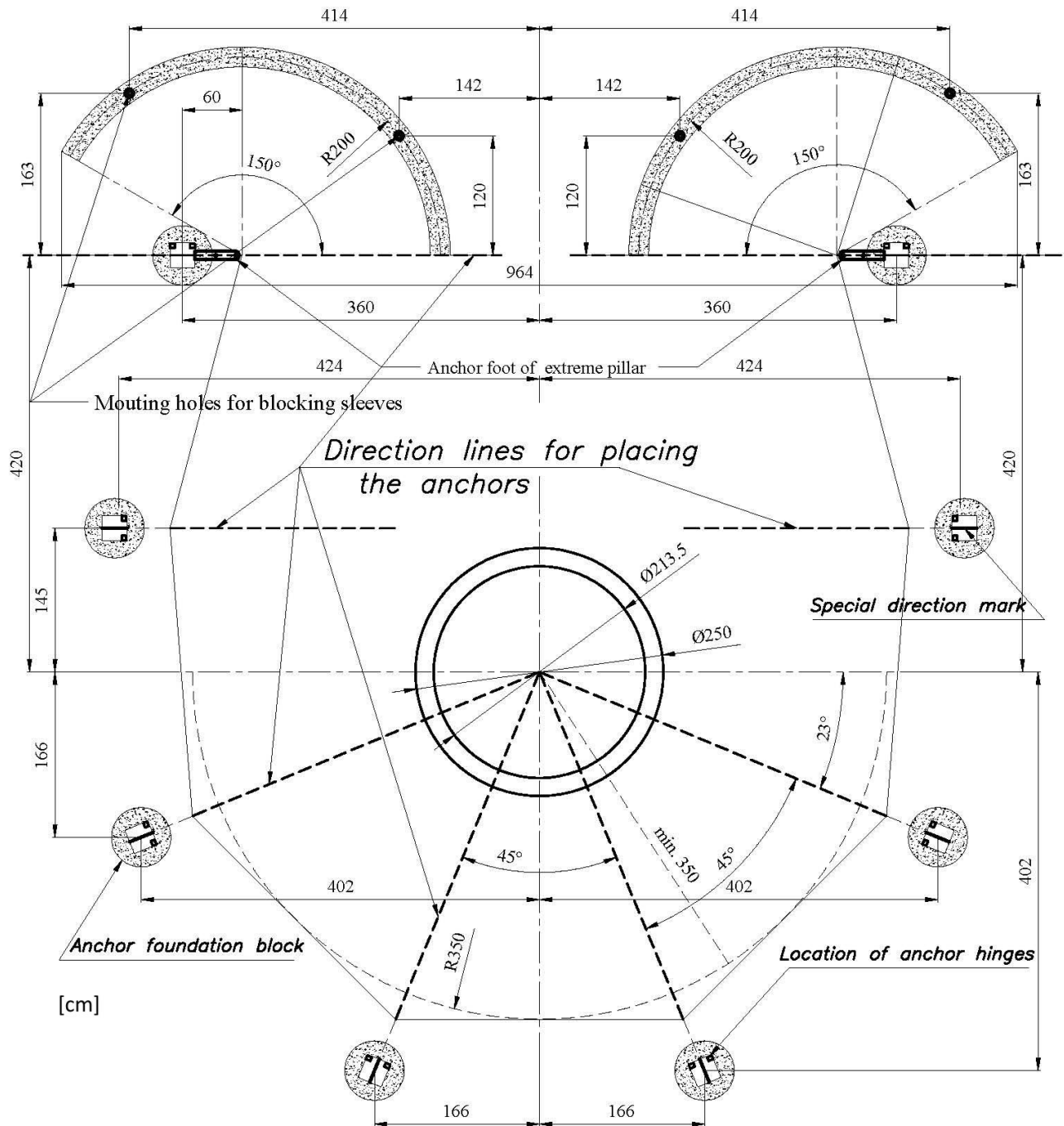

**Very important!**

We recommend that you should consult the way of placing anchors in concrete blocks and making paths for gate car wheels with geodesy expert in order to ensure that anchors and paths are correctly levelled, spaced and positioned according to the direction lines.

### Plan of the foundation blocks for cage pillars

### Drawing no. 6

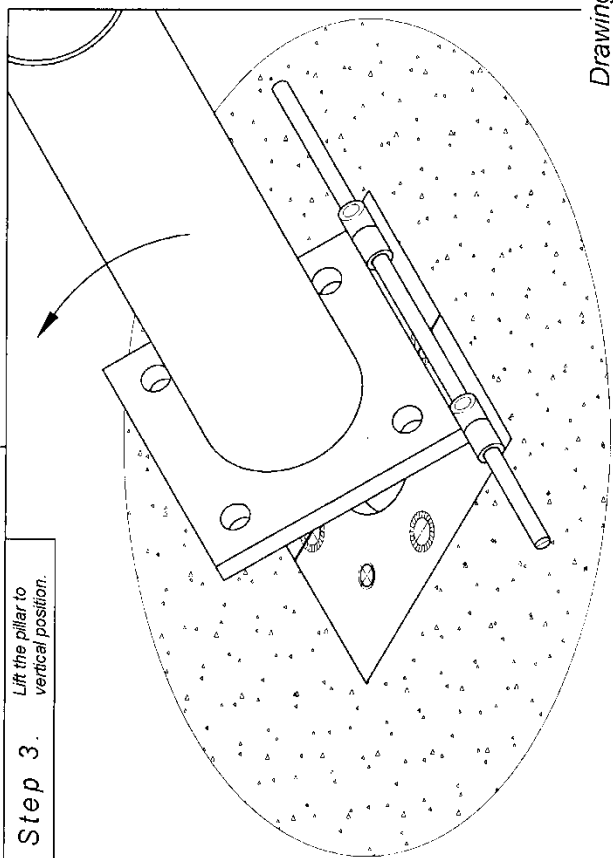
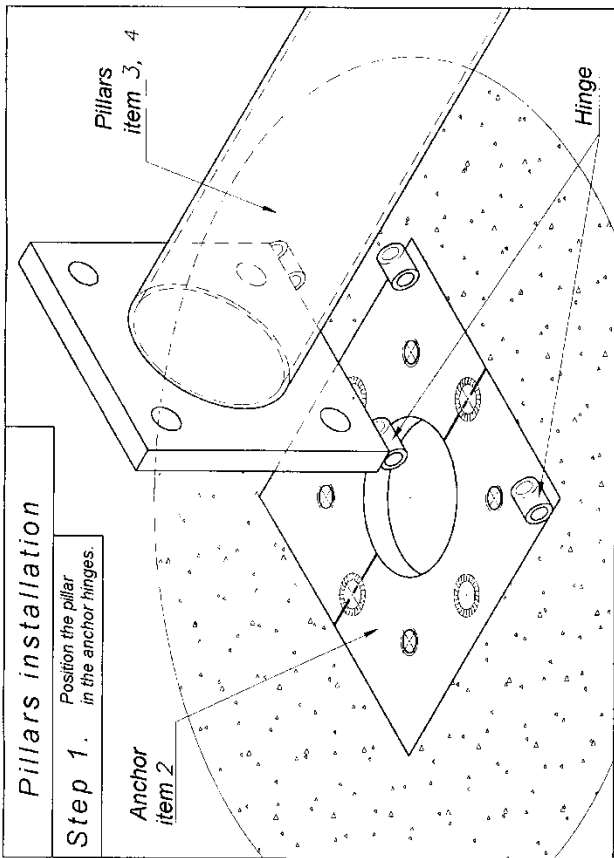
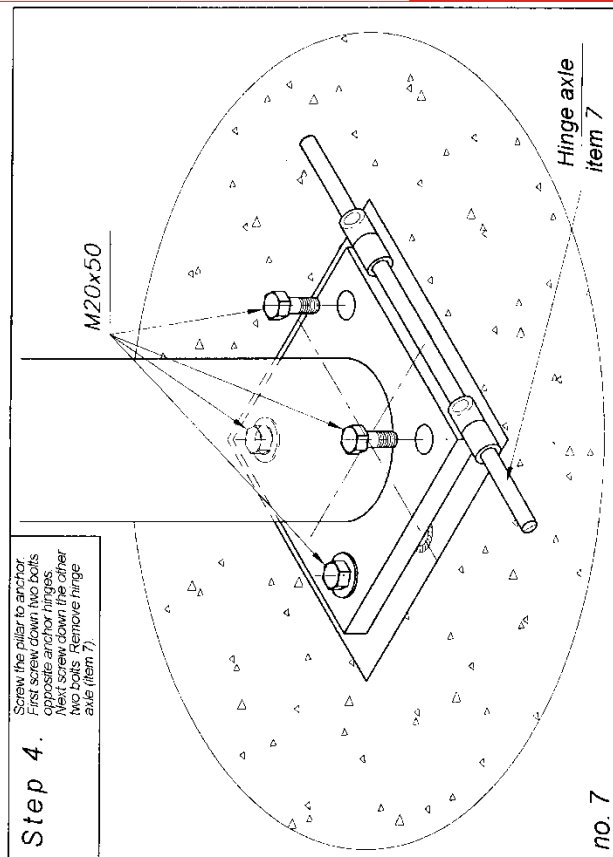
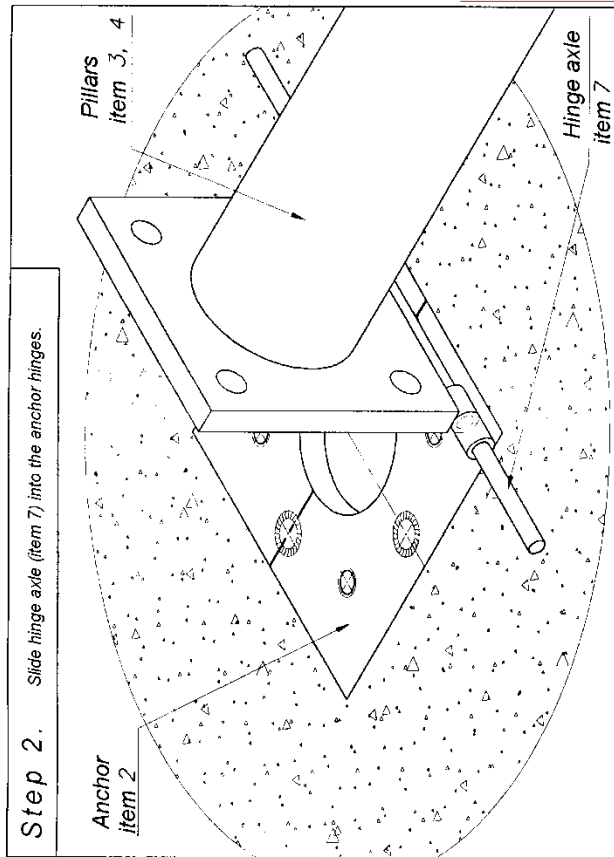

Drawing no. 7

## X. How to play the attached instructional video

The enclosed instructional CD can be viewed on VCD/DVD players and PC or MAC computers. If it does not start automatically, please explore CD main directory and click the file with .exe extension.

Minimal hardware requirements:

### PC

P166 MMX, 32 MB RAM, CD-ROM, VIDEO CARD  
WINDOWS 9x, NT 4.0, 2000, WINDOWS MEDIA PLAYER

### MAC

QUICK TIME PLAYER WITH QUICK TIME MPEG EXTENSION

You can also find on CD:

-IAAF certificate (in .jpg format)

-a copy of this assembly manual (in .pdf format – requires Acrobat Reader).

## XI. Declaration

1) No. 2020-08-26

2) Issuer's name: POLANIK Sp. z o. o.

Issuer's address: Życzliwa 11, 97-300 Piotrków Tryb.

3) Object of declaration:

No.	Description of goods	Code
1	Safety training cage for hammer and discus throw	KLM-5/7-A
2	Safety training cage for hammer and discus throw	KLM-7/9-A
3	Anchor set	K6-0027

4) The object of declaration described above is in conformity with the requirements of the following documents:

Articles	Document title	Issuer
37.1 37.2 37.5 37.6	Book C-C2.1 Technical Rules in force from 01.11.2019 amended 31.01.2020	World Athletics HQ 6-8, Quai Antoine 1er, BP 359, MC 98007 Monaco Cedex Tel: +377 93 10 88 88; Fax: +377 93 15 95 15

### Additional Information

5) Declaration for:

Buyer/Distributor/User

Signed for and in behalf of:

POLANIK

2020-08-26 Piotrków Tryb.  
(Date and place of issue)

6) Paweł Ciechanowski  
Product Manager

.....  
(Name, function)



.....  
(Signature or equivalent authorized by the issuer)