

INSTRUCTION MANUAL

Competition long jump and triple jump take-off board set with stainless steel foundation tray and plastic base board

S14-250 (ver. 2017)

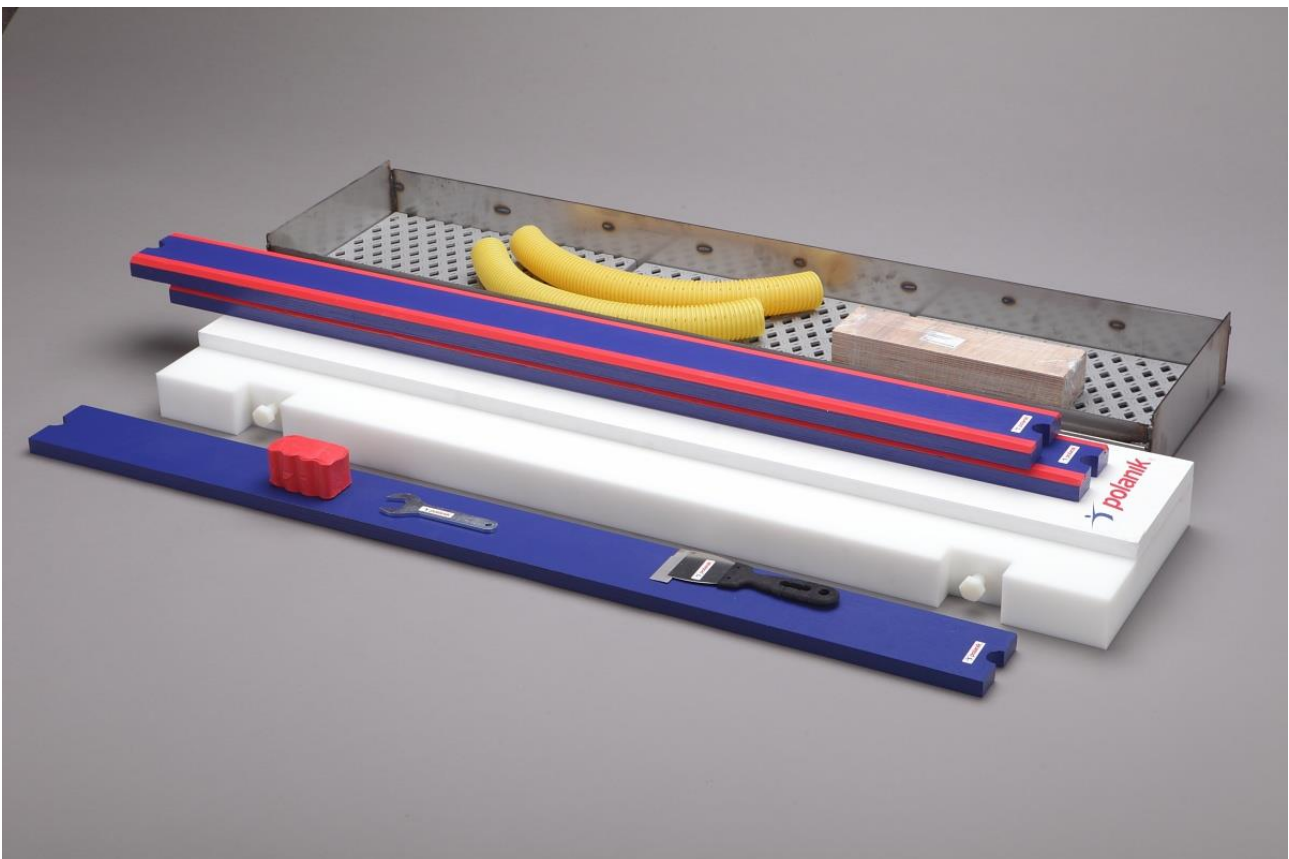

SAFER JUMPS TECHNOLOGY



Thank you for choosing Polanik competition take-off board S14-250.

Contents

Chapter	Page
I. General characteristics	2
II. Parts list (part sets)	3
III. Assembly and installation	4
IV. Remarks on maintenance and operating	8
V. Technical drawing - installed take-off board	9
VI. Additional equipment, available separately	10
VII. IAAF certificate	11

I. General characteristics



The take-off board S14-250 is designed for conducting sports events and training programs of horizontal jumps.
Main features of the take-off board:



- construction according to the latest safety recommendations – no metal elements in take-off zone, so foundation tray with lowered edges covered by synthetic surface and white take-off board fastened from the bottom side, no screws on top

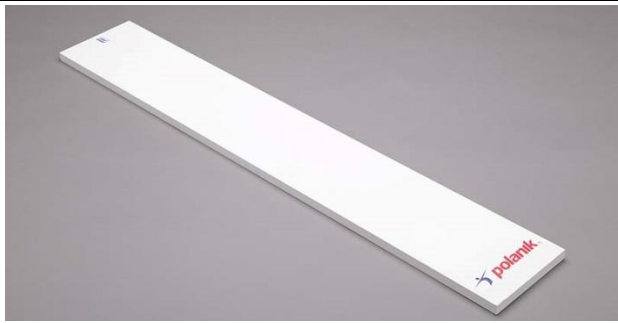
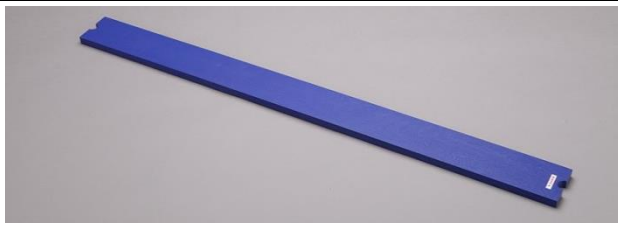

- innovative construction – constituted by elements which are easy to assemble, transport and store
- easy operating – fast assembly and disassembly processes, which take 15 minutes approx., can be done by one person provided that the foundation tray is already embedded in the track,
- high durability and quality – stainless steel foundation tray and plastic base board are waterproof and maintenance free elements, other parts are made of waterproof plywood and impregnated wood, the take-off board meets the international quality standards,
- fast replacement of wearing parts: white take-off board and indicator boards.

II. Parts list (part sets)

Item	Part/set description	Q-ty pcs	Part/set sketch
1	Stainless steel foundation tray with accessories for concreting (draining tubes and spacing boards) K3-250	1	
2	PCV base board K5-250	1	
3	White take-off board with screws K1-250	1	
4	Indicator plasticine board S-250-02-00	2	
5	Training indicator board without plasticine S-250-02-03	1	
6	Plasticine 300 g S-250-02-01	1	

Item	Part/set description	Q-ty pcs	Part/set sketch
7	Plasticine forming knife S-250-06-00	1	
8	Wrench - to block the supporting board in the tray S-0250-000-00-08-00	1	
9	Draining plastic grid S-250-03-00	3	

III. Assembly and installation

The sequence of the assembly operations is described in detail in this manual. The take-off board set is assembled for transport and includes all the mentioned elements. Before first use the foundation tray (item 1) is to be embedded in the track in the prescribed place, so that the take-off line – the edge of the white take-off board (item 3) which is closer to the landing pit, is in the distance of:

- 1 - 3 m (for long jump) to the landing pit edge that is closer to the take-off line – the IAAF international competition rules,
- 13 m (for men) and 11 m (for women) to the landing pit edge that is closer to the take-off line – the IAAF international competition rules.

For any other competition, the distance shall be adjusted to competitors` level.

The installation point of the tray (item 1) of the take-off board is presented below.

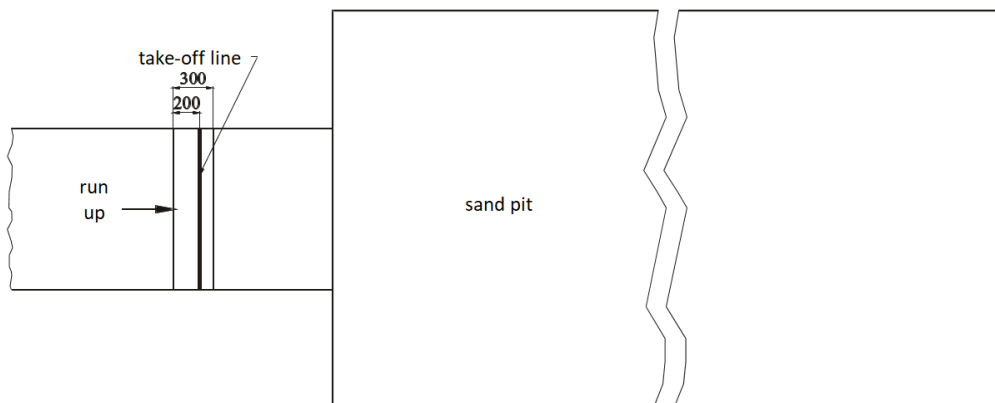

Drawing no. 1. Installing the take-off board – general view

ATTENTION!

The long side edges (B) of the foundation tray are 13 mm lower, they should be covered by synthetic surface. The short side edges (A) are to be flash with the top surface of the synthetic surface.

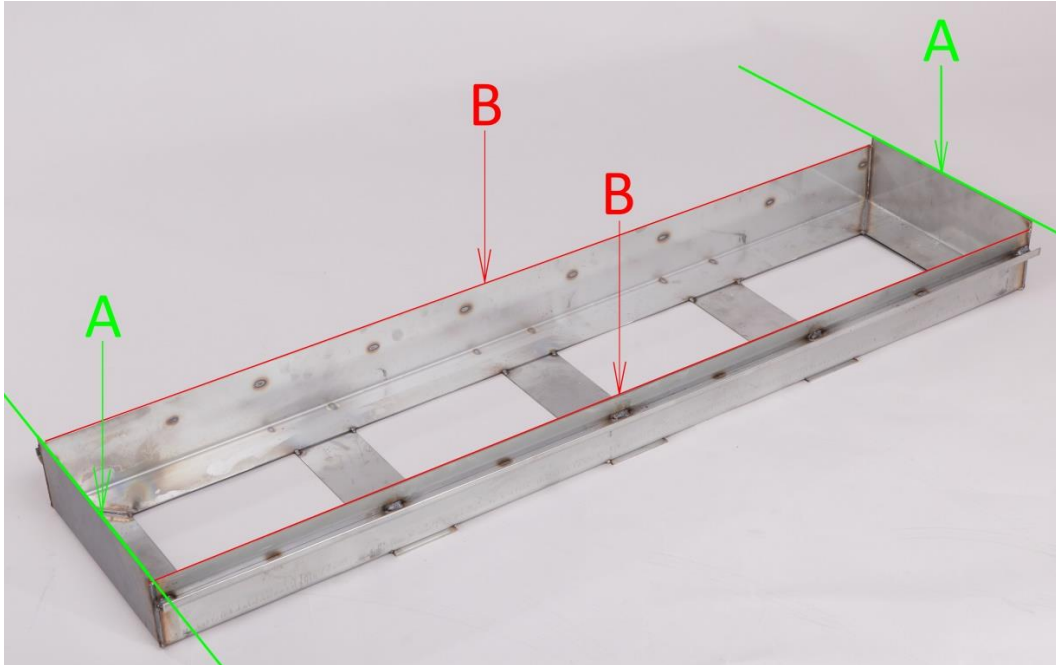

The tray should be positioned in the track and the inside of the tray must be secured with spacing boards (see image no. 1 and drawing no. 2), so that it does not deform while placing concrete. Deformations can make the plasticine board (item 4) or training board (item 5) block inside the tray.



Image 1. Installed tray secured with spacing boards

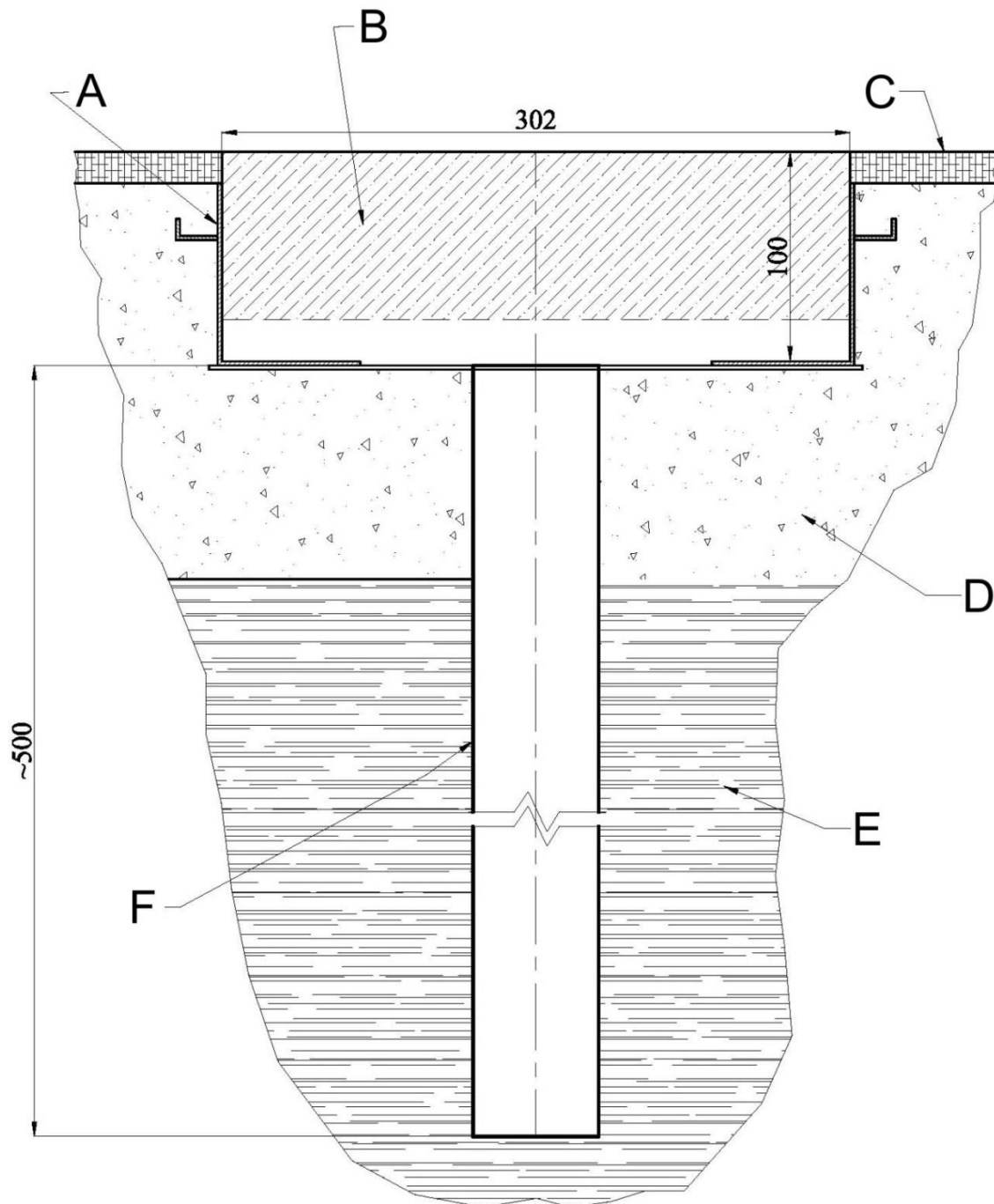

A – foundation tray
D – concrete

B – spacing board
E – ground

C – athletics synthetic surface
F – draining tube

Drawing no. 2. Embedding the foundation tray

Draining tubes ought to be positioned vertically in the spaces of the foundation tray and should go past the concrete layer. During the embedding process of the tray (item 1), draining tubes can stick out over the foundation tray bottom. After the concrete setting, the sticking tube ends are to be cut off as close to the tray bottom as possible to ensure the correct water outflow.

To install the take-off base board (item 2) with white take-off board (item 3) on top in the embedded tray (item 1) use a flat wrench no. 24 (item 8).



The installation begins with placing the plastic grids (item 9) in the embedded tray (item 1).

Next the plastic base board (item 2) with white take-off board (item 3) should be positioned on the plastic grids (item 9), so that the square heads of the adjusting bolts point the landing area.

The plastic base board (item 2) with white take-off board (item 3) is secured inside the tray (item 1) by means of the adjusting plastic bolts, use special wrench 24 included in the set (item 8). The bolts should be turned counterclockwise until the perceptible resistance occurs.

When the plastic base board (item 2) is properly mounted,

the indicator board (item 4 or item 5) can be put into the tray.

IV. Remarks on maintenance and operating

Plasticine strips deform during training sessions and competitions. There are two indicator plasticine boards (item 4), one training indicator board without plasticine (item 5), one plasticine block and one forming knife (item 7) in the set. Thanks to the two indicator boards you are able to replace the one with the deformed plasticine strips with the other one very quickly. It is recommended that one should substitute plasticine board (item 4) with indicator board without plasticine (item 5) for intensive training sessions. Training indicator board (item 5) is thinner and does not require the plasticine forming.

Dents and defects in the plasticine layers should be filled up and leveled. First one ought to apply thick layers of plasticine (item 6) on the damaged areas. Then the layers are to be leveled with the forming knife (item 7), as it is shown below.



Attention! While storing or using plasticine should be protected against high temperatures (over 40 °C), because otherwise it can change its shape and dimensions, and in extreme cases it can become a liquid.

To ensure great aesthetics and high comfort for jumpers we use natural raw materials like wood and plywood. The materials are not so durable as synthetic ones. Thus the wooden take-off board parts (white take-off board and indicator boards) wear out faster and they need to be replaced. In order to maintain the parts in good condition they should be removed from the embedded tray after competitions and training sessions and stored in a dry roofed place. It is recommended that the embedded stainless steel tray (item 1) should be sheltered with the stainless steel cover (see page 10). Any defects in paint coating revealed during thorough regular inspections of the wooden parts must be repaired with wood paint or impregnant. Synthetic base board (item 2), stainless steel foundation tray (item 1) and stainless steel blanking covers (available separately) do not require any additional maintenance actions.

Even though the wooden elements are impregnated and protected with paint, a prolonged contact with water can devastate or deform them.

The white take-off board (item 3) can be, turned over and screwed again to the plastic base board. That prolongs significantly the product's life.



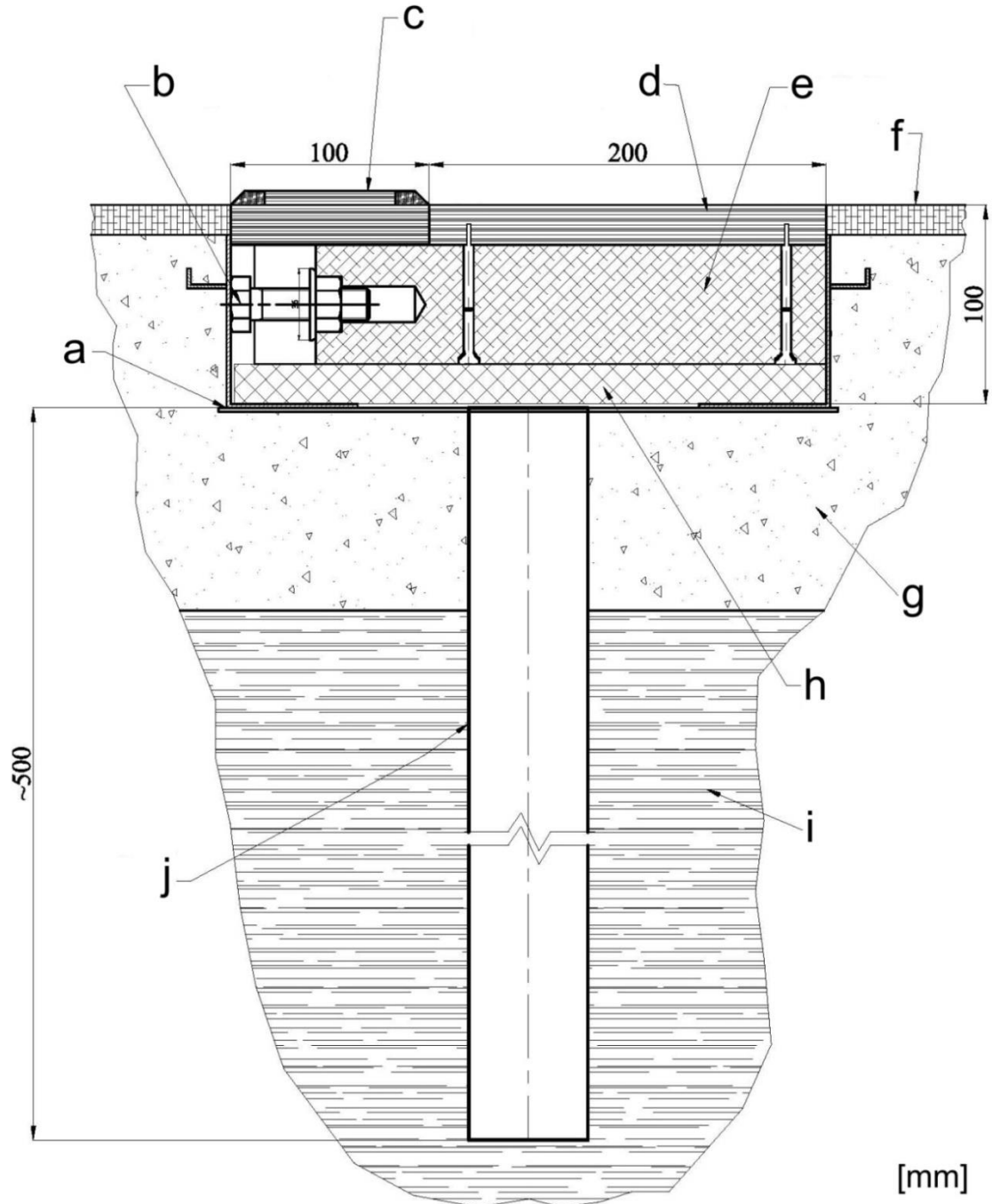

Even the best technical solutions cannot substitute for common sense. The usage of the product must take place under the supervision of qualified sports arena staff and trainers. The producer shall not be liable for any incidents caused by the improper take-off board installation, assembly or its misuse.

V. Technical drawing - installed take-off board



- a – stainless steel tray (item 1)
- b – adjusting bolt
- c – plasticine indicator board (item 4)
- d – white take-off board (item 3)
- e – synthetic base board (item 2)
- f – athletics synthetic surface
- g – concrete
- h – plastic grid (item 9)
- i – ground
- j – draining tube

VI. Additional equipment, available separately

Item	Part/set description	Part/set sketch
1	<p>Stainless steel cover for competition take-off board</p> <p>PBN-S0250</p> <p>Stainless steel cover for take-off competition boards, secures the inside of the board tray, smooth surface and 6 adjustable feet (in the range of 20 mm) for installing synthetic track, strong ribbed construction. Designed for gluing the synthetic surface.</p>	
2	<p>Stainless steel cover with edges for competition take-off board</p> <p>PBN14-S0250</p> <p>Stainless steel cover for take-off competition boards, secures the inside of the board tray, special edges for installing synthetic surface, 6 adjustable feet (in the range of 20 mm), strong ribbed construction. Equipped with edges for easy application of synthetic surface.</p>	
3	<p>Plasticine straps for indicator board</p> <p>P8x31</p> <p>Set of 8 red plasticine straps, specially shaped, ready to be put into the indicator board recess, designed for the competition take-off boards.</p>	
4	<p>Rubber indicator board for competition board</p> <p>LG15-250</p> <p>black full rubber indicator board designed for training</p>	

VII. IAAF certificate

International Association of Athletics Federations



Product Certificate

The IAAF is pleased to certify hereby that the following product:

Product's Trade Name: Fixed equipment, Take-off board, Competition

Description, Colour / Absolute Thickness: Plastic/plywood/stainless steel, White/dark blue

Company Name, Country: Polanik Sp. z o. o. - Sp. K., POL

Catalogue Number: S14-250

IAAF Certification Number: E-14-0775

meets the dimensional requirements for use in all international athletics competitions.

It is for the purchaser to determine the item's fitness for the purpose based on his knowledge of the local conditions and use.

Valid from: 1 February 2018

Until the last day of: February 2022

This certificate is issued in accordance with the terms and conditions of the IAAF Certification System of track and field facilities, implements and competition equipment.

SEBASTIAN COE
IAAF President

JORGE SALCEDO
IAAF Technical Committee Chairman

