

TECHNICAL SPECIFICATION INSTRUCTION MANUAL

One lane hurdle cart

S15-464



Presented hurdles are available separately.

File: 2015-05-14

PRODUCT SUPPORT
Paweł Ciechanowski
p.ciechanowski@polanik.com

I. General description and use

S15-464 has got a durable galvanized steel construction. It is equipped with an ergonomic handle. The cart is designed for transporting 10 hurdles for a athletics track lane.

II. Technical specification

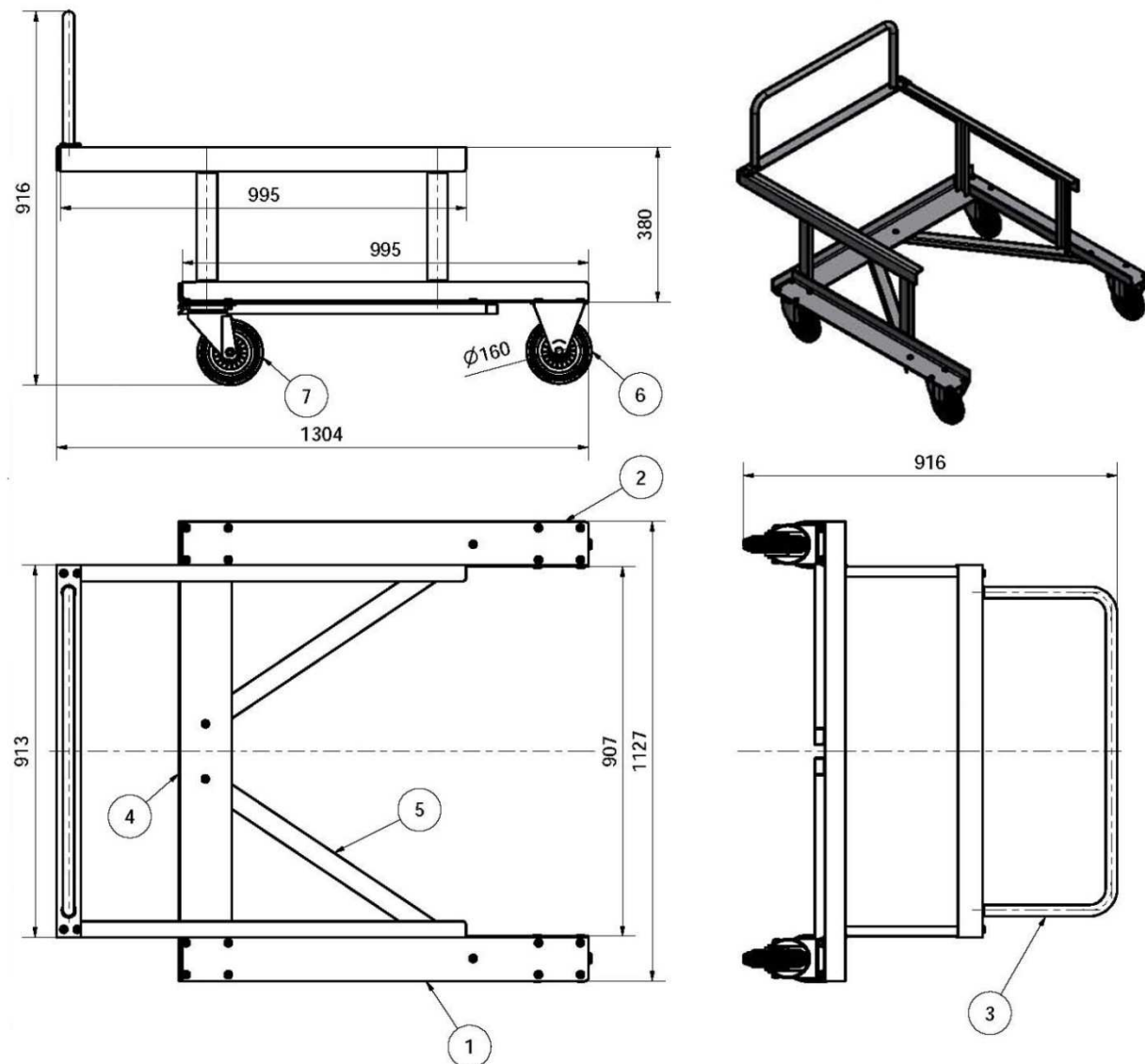

[mm]

1. Hurdle foot support (right)
2. Hurdle foot support (left)
3. Handle (additionally powder painted in red)
4. Front profile
5. Reinforcing profile
6. Full rubber wheel
7. Castoring full rubber wheel

Code	S15-464
Type	one lane hurdle cart
Construction	steel, galvanized
Use on	synthetic track
Capacity	min. 10 hurdles*
Handle	steel, galvanized and powder painted
Net weight [kg]	35

*apart from PP-170 series

III. Packing and transport

The product is packed in a carton box.

	Capacity	1 pc
Dimensions [m]	Length L	1,35
	Width B	0,46
	Height H	0,18
Volume [m ³]		0,11
Gross weight [kg]		37,8

IV. Assembly

The cart is delivered in parts. The parts are to be screwed together with the included screws, nuts and washers.

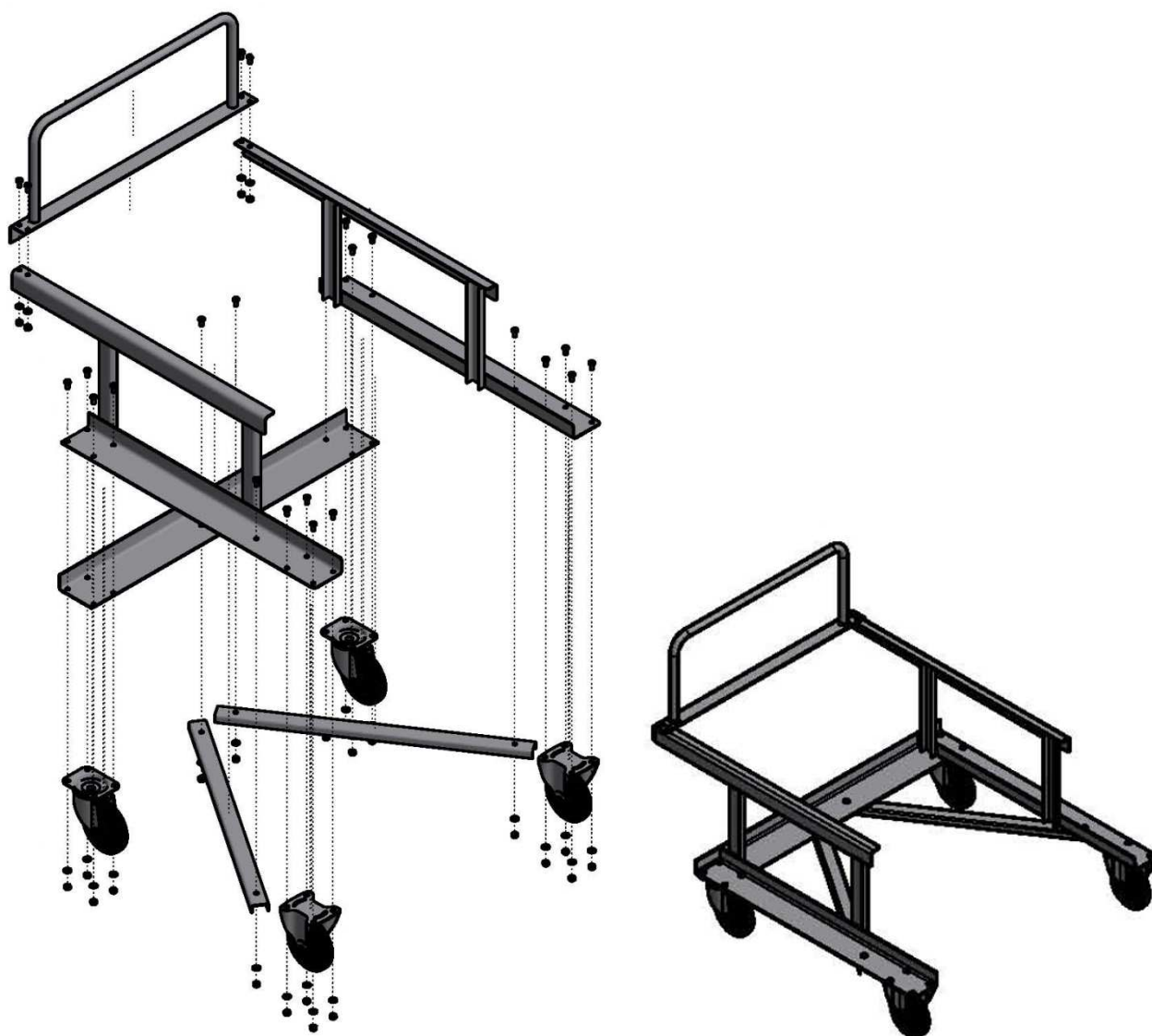

V. Operation

While you are placing hurdles on the cart, move them alternately to opposite sides, see the image below:



VI. Maintenance

The cart must be stored in a roofed and dry place.

VII. Declaration

1) No. 2015-11-20

2) Issuer's name: POLANIK

Issuer's address: Życzliwa 11, 97-300 Piotrkow Tryb.

3) Declared items

No.	Name	Code
1	One lane hurdle cart	S15-464

4) Technical specification described above is in accordance with the factory's internal engineering standard.

Additional information

5) The declaration was made for:

Purchaser and User

The declaration was signed on behalf and with authorization:

POLANIK

2015-11-20 Piotrkow Tryb.

(Date and place)

Paweł Ciechanowski

Product manager

6)

(Name, function)



(Signature or its equivalent authorized by the Exhibitor)